

## VRL SERIES

The VRL series is the all-rounder in the planetary gearbox marketplace. With helical gearing, robust internal construction, smooth operation and high torque density, this product is truly best-in-class. 5 arc-min backlash allows the VRL to be applied to a wide range of applications where accuracy and dynamics are in play, but cost is of concern.

The VRL is an excellent choice for servo applications in packaging, handling and automation systems. A variety of standard wash down and food grade options are available, making it an attractive option for the toughest environments. We offer the broadest selection of frame sizes and ratios, giving our customers more flexibility than ever before. Industry standard mounting dimensions allow the VRL to be implemented in legacy machine designs, saving our customers valuable time.

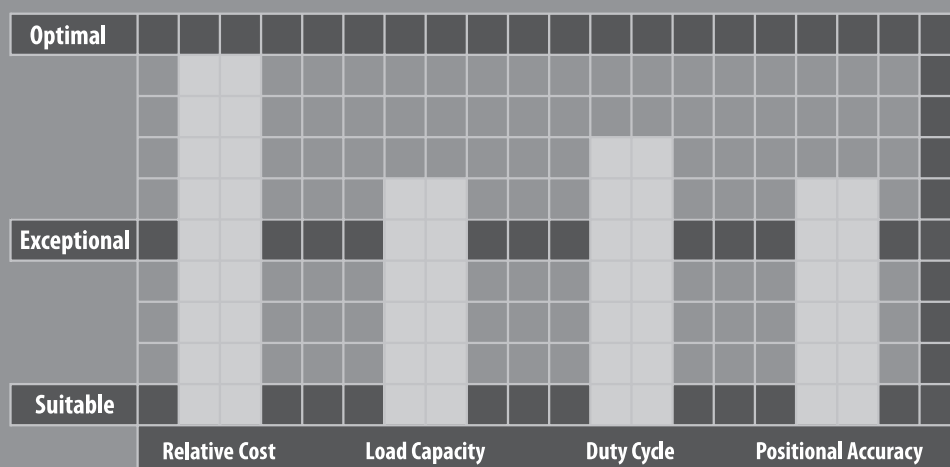



**VRL SERIES**

- The all-rounder for mid to high end motion control applications
- The widest range of frame sizes and ratios available in the market
- Best-In-class backlash ( $\leq 5$  arc-min)
- Broad range of mounting adapters offer a simple, precise attachment to any motor
- Maintenance-free solution that is lubricated for life. High performance grease allows flexible mounting in any orientation
- Industry standard mounting dimensions
- Assembled in the USA, with immediate delivery

# VRL SERIES Inline Planetary

## VRL Series Features

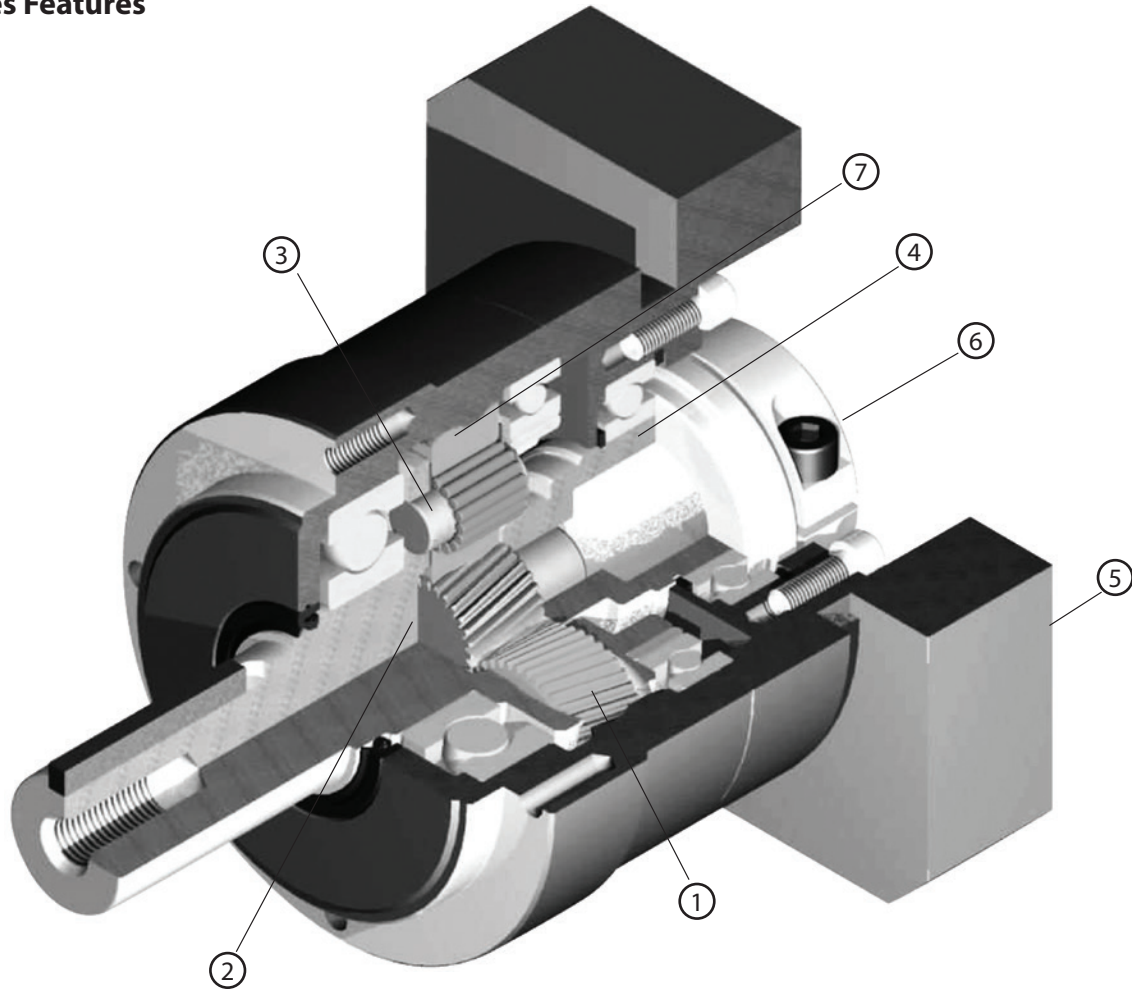

- ① Carburized helical gears with proprietary secondary finishing process for higher accuracy and smooth, quiet operation. 40% higher tooth surface area than the industry standard
- ② One piece output shaft and planet carrier with two bearings straddling the planet gears. Higher stiffness, torque capacity and safety factor, with guaranteed alignment of gearing
- ③ Uncaged needle roller bearings provide excellent torque density and torsional rigidity. 43% larger bearing surface area compared to the rest of the industry
- ④ Unique labyrinth input seal design greatly reduces heat and increases system efficiency. IP65 protection is available for wash down applications
- ⑤ Optimized mounting system with active centering on motor pilot diameter guarantees alignment of motor. Motor can be installed in any orientation
- ⑥ True concentric motor shaft clamping connection, optimized for your specific motor. Reduced inertia for dynamic performance and balanced for high speed operation
- ⑦ Ring gear machined directly into the housing, not welded or pressed in. Provides greater concentricity and elimination of speed fluctuation

## VRL Series Model Code

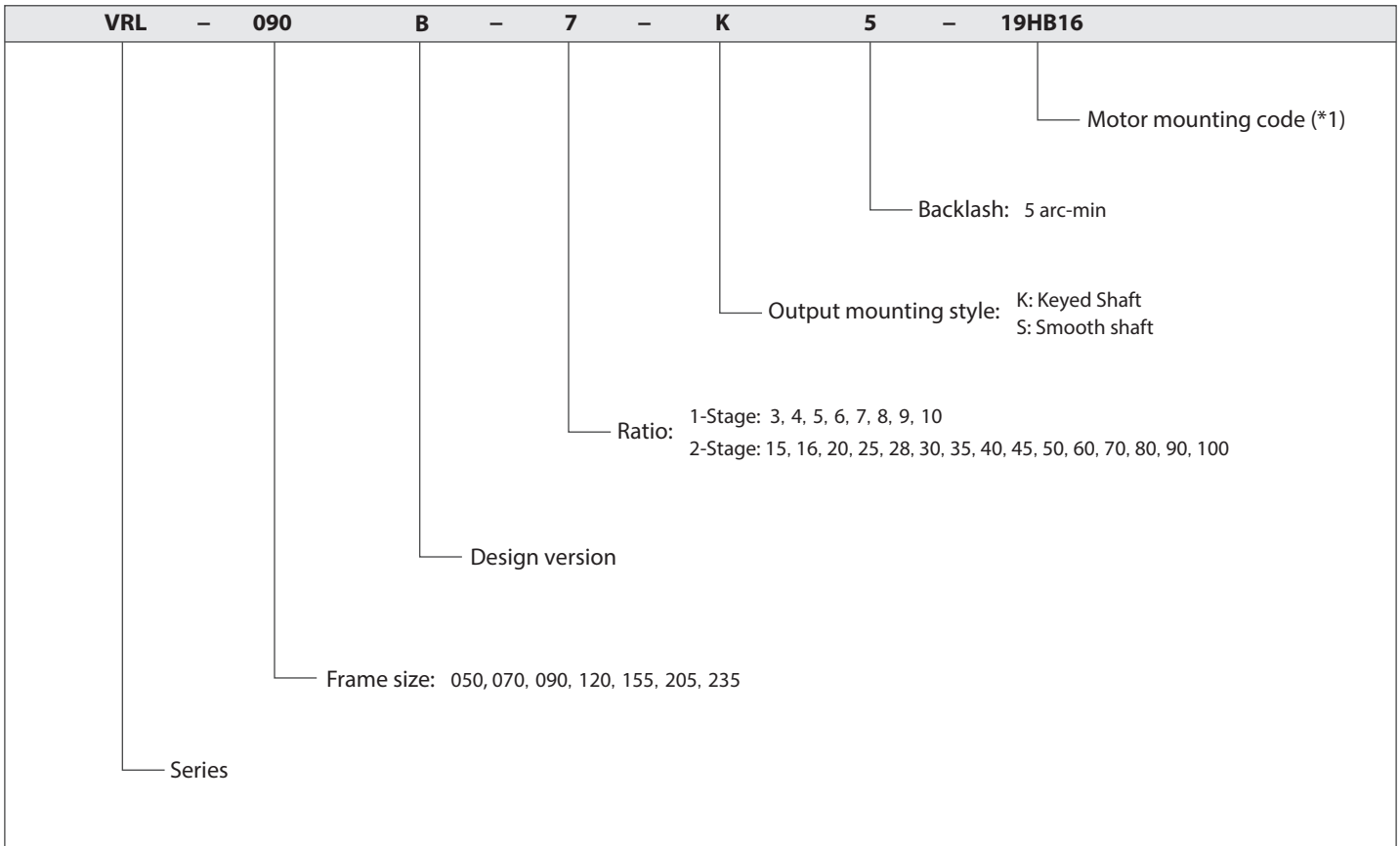

VRL

\*1) Motor mounting code varies depending on the motor. Use the selection tool link below to configure the code.

Contact us for additional information or refer to our online gearhead selection tool.  
Selection tool [www.nidec-shimpo.co.jp/selection/eng](http://www.nidec-shimpo.co.jp/selection/eng)

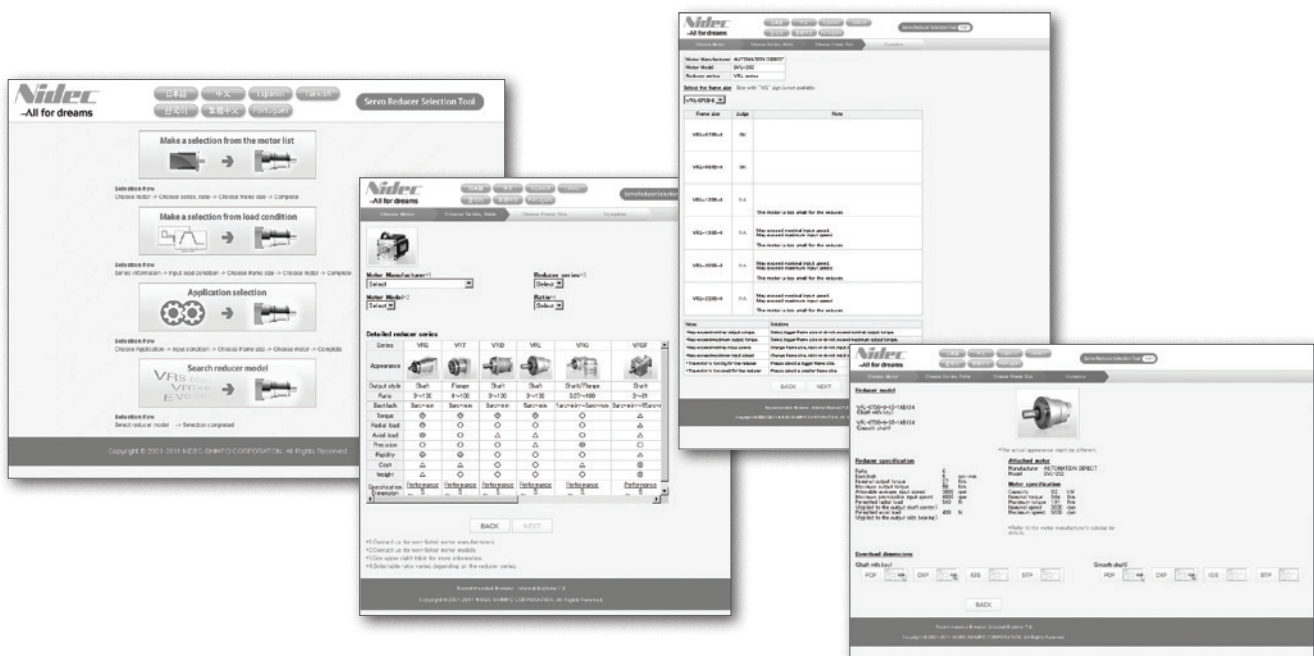

# VRL SERIES Inline Planetary

## VRL 050 1-Stage Specifications

Frame Size	050									
Stage	1-Stage									
Ratio	Units	Note	3	4	5	6	7	8	9	10
Nominal Output Torque	[Nm]	*1	6	9	9	9	9	9	6	6
Maximum Acceleration Torque	[Nm]	*2	12	18	18	18	18	18	12	12
Emergency Stop Torque	[Nm]	*3	30	35	35	35	35	35	30	30
Nominal Input Speed	[rpm]	*4	4000							
Maximum Input Speed	[rpm]	*5	8000							
No Load Running Torque	[Nm]	*6	0.03							
Permitted Radial Load	[N]	*7	240	270	290	310	320	340	350	360
Permitted Axial Load	[N]	*8	270	300	330	360	380	410	430	450
Maximum Radial Load	[N]	*9	710							
Maximum Axial Load	[N]	*10	640							
Moment of Inertia ( $\leq \emptyset 8$ )	[kgcm <sup>2</sup> ]	--	0.053	0.041	0.036	0.034	0.032	0.031	0.031	0.030
Moment of Inertia ( $\leq \emptyset 14$ )	[kgcm <sup>2</sup> ]	--	0.091	0.079	0.074	0.072	0.071	0.070	0.069	0.069
Efficiency	[%]	*11	95							
Torsional Rigidity	[Nm/arc-min]	*12	2							
Maximum Torsional Backlash	[arc-min]	--	$\leq 5$							
Noise Level	dB [A]	*13	$\leq 61$							
Protection Class	--	*14	IP54 (IP65)							
Ambient Temperature	[°C]	--	0-40							
Permitted Housing Temperature	[°C]	--	90							
Weight	[kg]	*15	0.7							

## VRL 050 2-Stage Specifications

Frame Size	050									
Stage	2-Stage									
Ratio	Units	Note	15	16	20	25	28	30	35	40
Nominal Output Torque	[Nm]	*1	6	9	9	9	9	9	9	9
Maximum Acceleration Torque	[Nm]	*2	12	18	18	18	18	12	18	18
Emergency Stop Torque	[Nm]	*3	30	35	35	35	35	30	35	35
Nominal Input Speed	[rpm]	*4	4000							
Maximum Input Speed	[rpm]	*5	8000							
No Load Running Torque	[Nm]	*6	0.01							
Permitted Radial Load	[N]	*7	410	420	460	490	510	520	550	570
Permitted Axial Load	[N]	*8	540	550	610	640	640	640	640	640
Maximum Radial Load	[N]	*9	710							
Maximum Axial Load	[N]	*10	640							
Moment of Inertia ( $\leq \emptyset 8$ )	[kgcm <sup>2</sup> ]	--	0.035	0.038	0.034	0.034	0.038	0.030	0.034	0.030
Moment of Inertia ( $\leq \emptyset 14$ )	[kgcm <sup>2</sup> ]	--	--	--	--	--	--	--	--	--
Efficiency	[%]	*11	90							
Torsional Rigidity	[Nm/arc-min]	*12	2							
Maximum Torsional Backlash	[arc-min]	--	$\leq 7$							
Noise Level	dB [A]	*13	$\leq 61$							
Protection Class	--	*14	IP54 (IP65)							
Ambient Temperature	[°C]	--	0-40							
Permitted Housing Temperature	[°C]	--	90							
Weight	[kg]	*15	0.8							

## VRL 050 2-Stage Specifications

Frame Size	050										
Stage	2-Stage										
Ratio	Units	Note	45	50	60	70	80	90	100		
Nominal Output Torque	[Nm]	*1	6	9	9	9	9	6	6		
Maximum Acceleration Torque	[Nm]	*2	12	18	18	18	18	12	12		
Emergency Stop Torque	[Nm]	*3	30	35	35	35	35	30	30		
Nominal Input Speed	[rpm]	*4	4000								
Maximum Input Speed	[rpm]	*5	8000								
No Load Running Torque	[Nm]	*6	0.01								
Permitted Radial Load	[N]	*7	600	620	660	690	710	710	710		
Permitted Axial Load	[N]	*8	640	640	640	640	640	640	640		
Maximum Radial Load	[N]	*9	710								
Maximum Axial Load	[N]	*10	640								
Moment of Inertia ( $\leq \varnothing 8$ )	[kgcm <sup>2</sup> ]	--	0.034	0.030	0.030	0.030	0.030	0.030	0.030		
Moment of Inertia ( $\leq \varnothing 14$ )	[kgcm <sup>2</sup> ]	--	--	--	--	--	--	--	--		
Efficiency	[%]	*11	90								
Torsional Rigidity	[Nm/arc-min]	*12	2								
Maximum Torsional Backlash	[arc-min]	--	$\leq 7$								
Noise Level	dB [A]	*13	$\leq 61$								
Protection Class	--	*14	IP54 (IP65)								
Ambient Temperature	[°C]	--	0-40								
Permitted Housing Temperature	[°C]	--	90								
Weight	[kg]	*15	0.8								

- \*1) At nominal input speed, service life is 20,000 hours
- \*2) The maximum torque when starting or stopping operation
- \*3) The maximum torque allowed under a stress situation (Permitted 1,000 times during service life)
- \*4) The average input speed
- \*5) The maximum intermittent input speed
- \*6) Torque at no load applied to the input shaft at nominal input speed
- \*7) At this load and nominal input speed, service life will be 20,000 hours. (The radial load applied to the output side shaft center)
- \*8) At this load and nominal input speed, service life will be 20,000 hours. (The axial load applied to the output side bearing)
- \*9) The maximum radial load that the gearbox can accept
- \*10) The maximum axial load that the gearbox can accept
- \*11) The efficiency at the nominal output torque rating
- \*12) This does not include lost motion
- \*13) Contact NIDEC-SHIMPO for the testing conditions and environment
- \*14) IP65 (wash-down) is available as an option. Contact NIDEC-SHIMPO for more details
- \*15) The weight may vary slightly between models

# VRL SERIES Inline Planetary

## VRL 050 1-Stage Dimensions

Input bore size  $\leq \phi 8$  mm

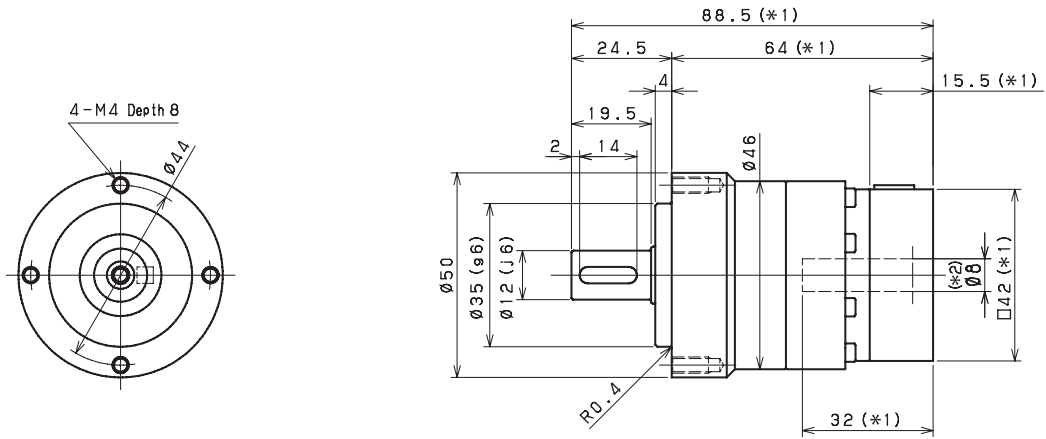

Input bore size  $\leq \phi 14$  mm

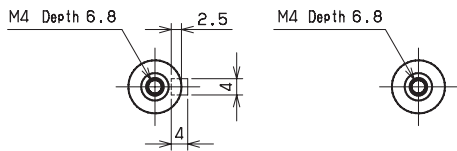
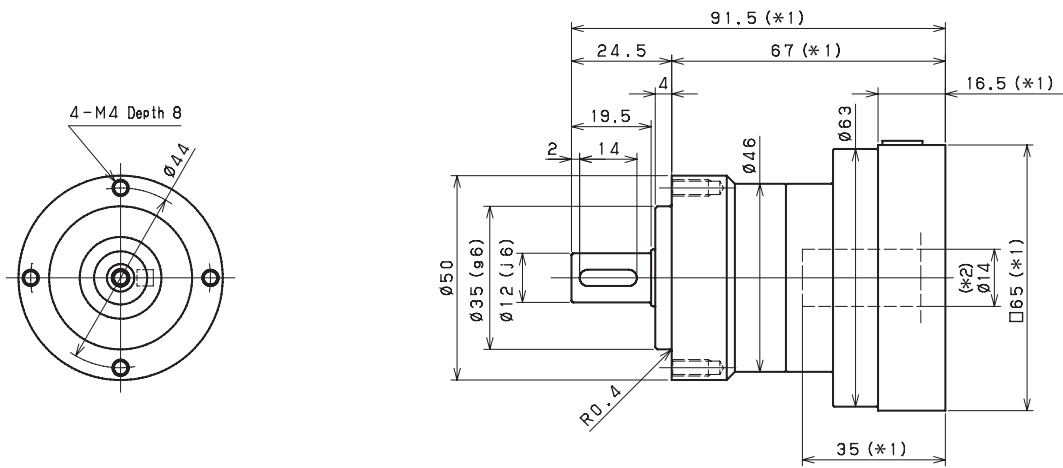

Keyed shaft

Smooth shaft

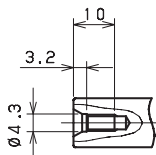

\*1) Length will vary depending on motor

\*2) Bushing will be inserted to adapt to motor shaft

## VRL 050 2-Stage Dimensions

VRL

Input bore size  $\leq \phi 8$  mm

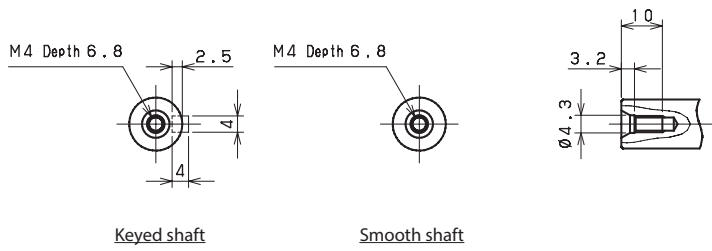
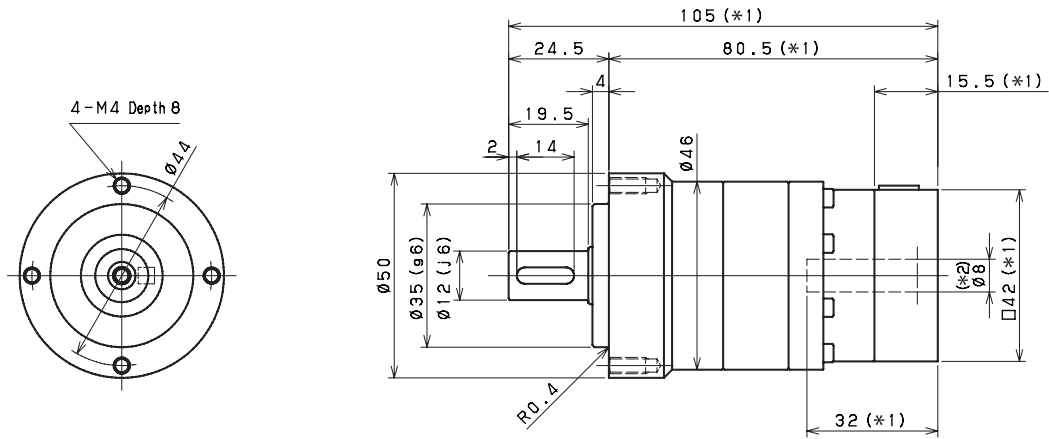

- \*1) Length will vary depending on motor
- \*2) Bushing will be inserted to adapt to motor shaft



# VRL SERIES Inline Planetary

## VRL 070 1-Stage Specifications

Frame Size	070									
Stage	1-Stage									
Ratio	Unit	Note	3	4	5	6	7	8	9	10
Nominal Output Torque	[Nm]	*1	18	27	27	27	27	27	18	18
Maximum Output Torque	[Nm]	*2	35	50	50	50	50	50	35	35
Emergency Stop Torque	[Nm]	*3	80	100	100	100	100	100	80	80
Nominal Input Speed	[rpm]	*4	3000							
Maximum Input Speed	[rpm]	*5	6000							
No Load Running Torque	[Nm]	*6	0.08							
Permitted Radial Load	[N]	*7	430	470	510	540	570	600	620	640
Permitted Axial Load	[N]	*8	310	360	390	430	460	480	510	530
Maximum Radial Load	[N]	*9	1200							
Maximum Axial Load	[N]	*10	1100							
Moment of Inertia ( $\leq \emptyset 8$ )	[kgcm <sup>2</sup> ]	--	0.140	0.095	0.077	0.068	0.062	0.059	0.057	0.056
Moment of Inertia ( $\leq \emptyset 14$ )	[kgcm <sup>2</sup> ]	--	0.220	0.170	0.160	0.150	0.140	0.140	0.140	0.140
Moment of Inertia ( $\leq \emptyset 19$ )	[kgcm <sup>2</sup> ]	--	0.430	0.380	0.360	0.360	0.350	0.350	0.340	0.340
Efficiency	[%]	*11	95							
Torsional Rigidity	[Nm/arcmin]	*12	3							
Maximum Torsional Backlash	[Arc-min]	--	$\leq 5$							
Noise Level	dB [A]	*13	$\leq 66$							
Protection Class	--	*14	IP54 (IP65)							
Ambient Temperature	[°C]	--	0-40							
Permitted Housing Temperature	[°C]	--	90							
Weight	[kg]	*15	1.5							

## VRL 070 2-Stage Specifications

Frame Size	070									
Stage	2-Stage									
Ratio	Unit	Note	15	16	20	25	28	30	35	40
Nominal Output Torque	[Nm]	*1	18	27	27	27	27	18	27	27
Maximum Output Torque	[Nm]	*2	35	50	50	50	50	35	50	50
Emergency Stop Torque	[Nm]	*3	80	100	100	100	100	80	100	100
Nominal Input Speed	[rpm]	*4	3000							
Maximum Input Speed	[rpm]	*5	6000							
No Load Running Torque	[Nm]	*6	0.04							
Permitted Radial Load	[N]	*7	740	750	810	870	910	930	980	1000
Permitted Axial Load	[N]	*8	630	650	720	790	830	860	920	970
Maximum Radial Load	[N]	*9	1200							
Maximum Axial Load	[N]	*10	1100							
Moment of Inertia ( $\leq \emptyset 8$ )	[kgcm <sup>2</sup> ]	--	0.055	0.057	0.054	0.053	0.055	0.049	0.053	0.049
Moment of Inertia ( $\leq \emptyset 14$ )	[kgcm <sup>2</sup> ]	--	0.140	0.140	0.130	0.130	0.140	0.130	0.130	0.130
Moment of Inertia ( $\leq \emptyset 19$ )	[kgcm <sup>2</sup> ]	--	0.350	0.360	0.350	0.350	0.360	0.340	0.350	0.340
Efficiency	[%]	*11	90							
Torsional Rigidity	[Nm/arcmin]	*12	3							
Maximum Torsional Backlash	[Arc-min]	--	$\leq 5$							
Noise Level	dB [A]	*13	$\leq 66$							
Protection Class	--	*14	IP54 (IP65)							
Ambient Temperature	[°C]	--	0-40							
Permitted Housing Temperature	[°C]	--	90							
Weight	[kg]	*15	1.7							

## VRL 070 2-Stage Specifications

Frame Size	070										
Stage	2-Stage										
Ratio	Unit	Note	45	50	60	70	80	90	100		
Nominal Output Torque	[Nm]	*1	18	27	27	27	27	18	18		
Maximum Output Torque	[Nm]	*2	35	50	50	50	50	35	35		
Emergency Stop Torque	[Nm]	*3	80	100	100	100	100	80	80		
Nominal Input Speed	[rpm]	*4	3000								
Maximum Input Speed	[rpm]	*5	6000								
No Load Running Torque	[Nm]	*6	0.04								
Permitted Radial Load	[N]	*7	1100	1100	1200	1200	1200	1200	1200		
Permitted Axial Load	[N]	*8	1000	1100	1100	1100	1100	1100	1100		
Maximum Radial Load	[N]	*9	1200								
Maximum Axial Load	[N]	*10	1100								
Moment of Inertia ( $\leq \varnothing 8$ )	[kgcm <sup>2</sup> ]	--	0.053	0.049	0.049	0.049	0.049	0.049	0.049		
Moment of Inertia ( $\leq \varnothing 14$ )	[kgcm <sup>2</sup> ]	--	0.130	0.130	0.130	0.130	0.130	0.13	0.13		
Moment of Inertia ( $\leq \varnothing 19$ )	[kgcm <sup>2</sup> ]	--	0.350	0.340	0.340	0.340	0.340	0.340	0.340		
Efficiency	[%]	*11	90								
Torsional Rigidity	[Nm/arcmin]	*12	3								
Maximum Torsional Backlash	[Arc-min]	--	$\leq 5$								
Noise Level	dB [A]	*13	$\leq 66$								
Protection Class	--	*14	IP54 (IP65)								
Ambient Temperature	[°C]	--	0-40								
Permitted Housing Temperature	[°C]	--	90								
Weight	[kg]	*15	1.7								

- \*1) At nominal input speed, service life is 20,000 hours
- \*2) The maximum torque when starting or stopping operation
- \*3) The maximum torque allowed under a stress situation (Permitted 1,000 times during service life)
- \*4) The average input speed
- \*5) The maximum intermittent input speed
- \*6) Torque at no load applied to the input shaft at nominal input speed
- \*7) At this load and nominal input speed, service life will be 20,000 hours. (The radial load applied to the output side shaft center)
- \*8) At this load and nominal input speed, service life will be 20,000 hours. (The axial load applied to the output side bearing)
- \*9) The maximum radial load that the gearbox can accept
- \*10) The maximum axial load that the gearbox can accept
- \*11) The efficiency at the nominal output torque rating
- \*12) This does not include lost motion
- \*13) Contact NIDEC-SHIMPO for the testing conditions and environment
- \*14) IP65 (wash-down) is available as an option. Contact NIDEC-SHIMPO for more details
- \*15) The weight may vary slightly between models

# VRL SERIES Inline Planetary

## VRL 070 1-Stage Dimensions

Input bore size  $\leq \varnothing 8 \text{ mm}$

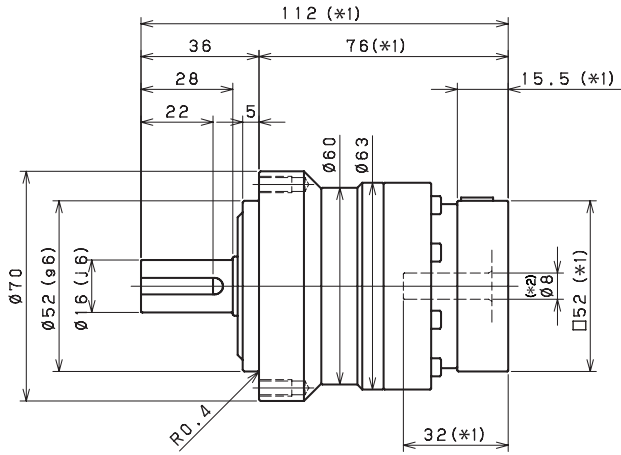
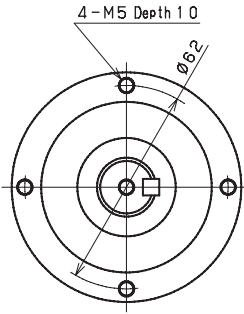

Input bore size  $\leq \varnothing 14 \text{ mm}$

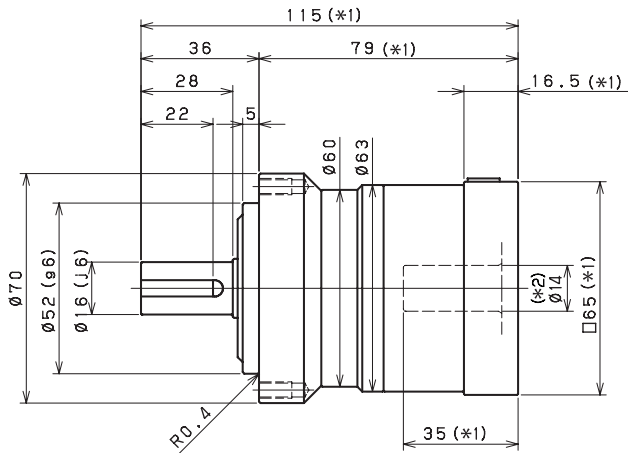
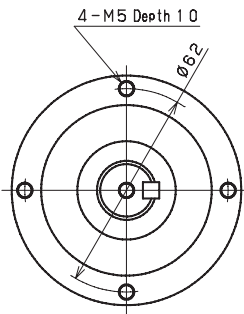

Input bore size  $\leq \varnothing 19 \text{ mm}$

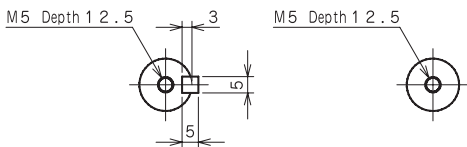
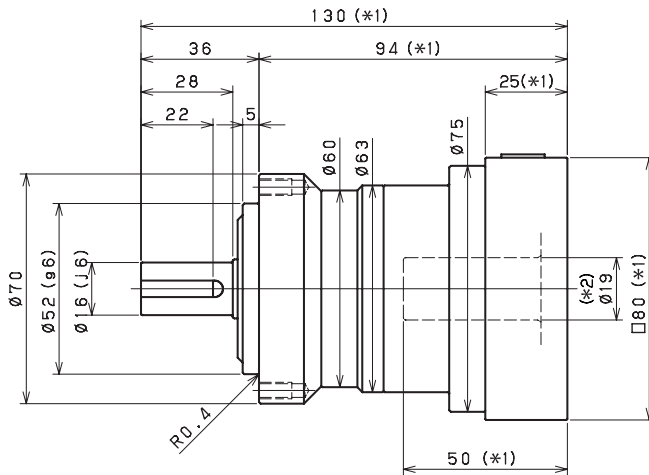
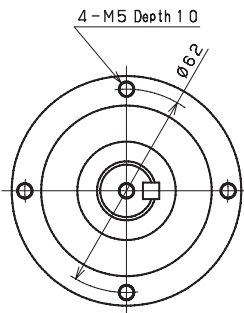

Keyed shaft

Smooth shaft

\*1) Length will vary depending on motor

\*2) Bushing will be inserted to adapt to motor shaft

## VRL 070 2-Stage Dimensions

Input bore size  $\leq \phi 8$  mm

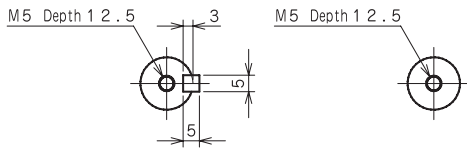
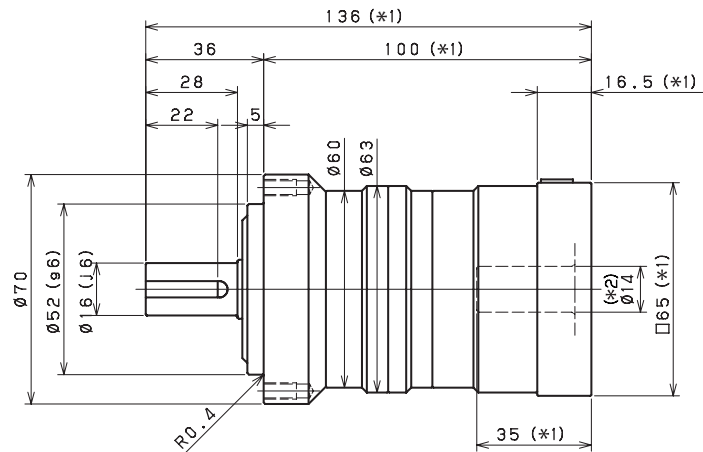
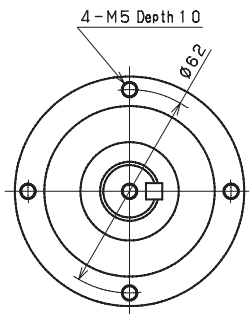
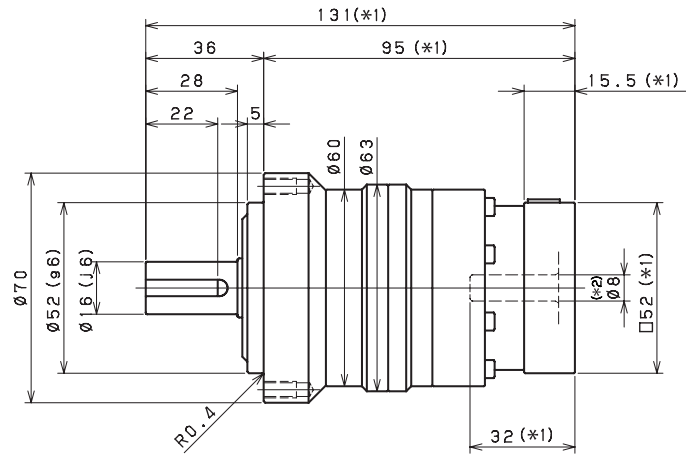
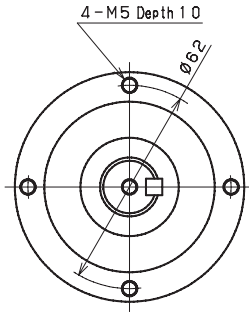

Keyed shaft

Smooth shaft

\*1) Length will vary depending on motor

\*2) Bushing will be inserted to adapt to motor shaft

# VRL SERIES Inline Planetary

## VRL 090 1-Stage Specifications

Frame Size	090											
Stage	1-Stage											
Ratio	Unit	Note	3	4	5	6	7	8	9	10		
Nominal Output Torque	[Nm]	*1	50	75	75	75	75	75	50	50		
Maximum Acceleration Torque	[Nm]	*2	80	125	125	125	125	125	80	80		
Emergency Stop Torque	[Nm]	*3	200	250	250	250	250	250	200	200		
Nominal Input Speed	[rpm]	*4	3000									
Maximum Input Speed	[rpm]	*5	6000									
No Load Running Torque	[Nm]	*6	0.35									
Permitted Radial Load	[N]	*7	810	890	960	1000	1100	1100	1200	1200		
Permitted Axial Load	[N]	*8	930	1100	1200	1300	1300	1400	1500	1600		
Maximum Radial Load	[N]	*9	2400									
Maximum Axial Load	[N]	*10	2200									
Moment of Inertia ( $\leq \emptyset 8$ )	[kgcm <sup>2</sup> ]	--	--	--	--	--	--	--	--	--		
Moment of Inertia ( $\leq \emptyset 14$ )	[kgcm <sup>2</sup> ]	--	0.720	0.490	0.400	0.360	0.320	0.310	0.290	0.290		
Moment of Inertia ( $\leq \emptyset 19$ )	--	--	1.200	0.950	0.860	0.820	0.790	0.770	0.760	0.750		
Moment of Inertia ( $\leq \emptyset 28$ )	[kgcm <sup>2</sup> ]	--	3.200	3.000	2.900	2.800	2.800	2.800	2.800	2.800		
Efficiency	[%]	*11	95									
Torsional Rigidity	[Nm/arc-min]	*12	10									
Maximum Torsional Backlash	[arc-min]	--	$\leq 5$									
Noise Level	dB [A]	*13	$\leq 67$									
Protection Class	--	*14	IP54 (IP65)									
Ambient Temperature	[°C]	--	0-40									
Permitted Housing Temperature	[°C]	--	90									
Weight	[kg]	*15	3.5									

## VRL 090 2-Stage Specifications

Frame Size	090											
Stage	2-Stage											
Ratio	Unit	Note	15	16	20	25	28	30	35	40		
Nominal Output Torque	[Nm]	*1	50	75	75	75	75	50	75	75		
Maximum Acceleration Torque	[Nm]	*2	80	125	125	125	125	80	125	125		
Emergency Stop Torque	[Nm]	*3	200	250	250	250	250	200	250	250		
Nominal Input Speed	[rpm]	*4	3000									
Maximum Input Speed	[rpm]	*5	6000									
No Load Running Torque	[Nm]	*6	0.06									
Permitted Radial Load	[N]	*7	1400	1400	1500	1600	1700	1700	1800	1900		
Permitted Axial Load	[N]	*8	1900	1900	2100	2200	2200	2200	2200	2200		
Maximum Radial Load	[N]	*9	2400									
Maximum Axial Load	[N]	*10	2200									
Moment of Inertia ( $\leq \emptyset 8$ )	[kgcm <sup>2</sup> ]	--	0.130	0.150	0.130	0.120	0.140	0.100	0.120	0.099		
Moment of Inertia ( $\leq \emptyset 14$ )	[kgcm <sup>2</sup> ]	--	0.280	0.300	0.280	0.280	0.290	0.250	0.270	0.250		
Moment of Inertia ( $\leq \emptyset 19$ )	--	--	0.720	0.740	0.720	0.710	0.730	0.700	0.710	0.700		
Moment of Inertia ( $\leq \emptyset 28$ )	[kgcm <sup>2</sup> ]	--	2.700	2.800	2.700	2.700	2.700	2.600	2.700	2.600		
Efficiency	[%]	*11	90									
Torsional Rigidity	[Nm/arc-min]	*12	10									
Maximum Torsional Backlash	[arc-min]	--	$\leq 5$									
Noise Level	dB [A]	*13	$\leq 67$									
Protection Class	--	*14	IP54 (IP65)									
Ambient Temperature	[°C]	--	0-40									
Permitted Housing Temperature	[°C]	--	90									
Weight	[kg]	*15	4									

## VRL 090 2-Stage Specifications

Frame Size	090										
Stage	2-Stage										
Ratio	Unit	Note	45	50	60	70	80	90	100		
Nominal Output Torque	[Nm]	*1	50	75	75	75	75	50	50		
Maximum Acceleration Torque	[Nm]	*2	80	125	125	125	125	80	80		
Emergency Stop Torque	[Nm]	*3	200	250	250	250	250	200	200		
Nominal Input Speed	[rpm]	*4	3000								
Maximum Input Speed	[rpm]	*5	6000								
No Load Running Torque	[Nm]	*6	0.06								
Permitted Radial Load	[N]	*7	2000	2100	2200	2300	2400	2400	2400		
Permitted Axial Load	[N]	*8	2200	2200	2200	2200	2200	2200	2200		
Maximum Radial Load	[N]	*9	2400								
Maximum Axial Load	[N]	*10	2200								
Moment of Inertia ( $\leq \varnothing 8$ )	[kgcm <sup>2</sup> ]	--	0.120	0.098	0.098	0.097	0.097	0.097	0.097		
Moment of Inertia ( $\leq \varnothing 14$ )	[kgcm <sup>2</sup> ]	--	0.270	0.250	0.250	0.250	0.250	0.250	0.250		
Moment of Inertia ( $\leq \varnothing 19$ )	--	--	0.710	0.690	0.690	0.690	0.690	0.690	0.690		
Moment of Inertia ( $\leq \varnothing 28$ )	[kgcm <sup>2</sup> ]	--	2.700	2.600	2.600	2.600	2.600	2.600	2.600		
Efficiency	[%]	*11	90								
Torsional Rigidity	[Nm/arc-min]	*12	10								
Maximum Torsional Backlash	[arc-min]	--	$\leq 5$								
Noise Level	dB [A]	*13	$\leq 67$								
Protection Class	--	*14	IP54 (IP65)								
Ambient Temperature	[°C]	--	0-40								
Permitted Housing Temperature	[°C]	--	90								
Weight	[kg]	*15	4								

- \*1) At nominal input speed, service life is 20,000 hours
- \*2) The maximum torque when starting or stopping operation
- \*3) The maximum torque allowed under a stress situation (Permitted 1,000 times during service life)
- \*4) The average input speed
- \*5) The maximum intermittent input speed
- \*6) Torque at no load applied to the input shaft at nominal input speed
- \*7) At this load and nominal input speed, service life will be 20,000 hours. (The radial load applied to the output side shaft center)
- \*8) At this load and nominal input speed, service life will be 20,000 hours. (The axial load applied to the output side bearing)
- \*9) The maximum radial load that the gearbox can accept
- \*10) The maximum axial load that the gearbox can accept
- \*11) The efficiency at the nominal output torque rating
- \*12) This does not include lost motion
- \*13) Contact NIDEC-SHIMPO for the testing conditions and environment
- \*14) IP65 (wash-down) is available as an option. Contact NIDEC-SHIMPO for more details
- \*15) The weight may vary slightly between models



## VRL 090 2-Stage Dimensions

Input bore size  $\leq \varnothing 8$  mm

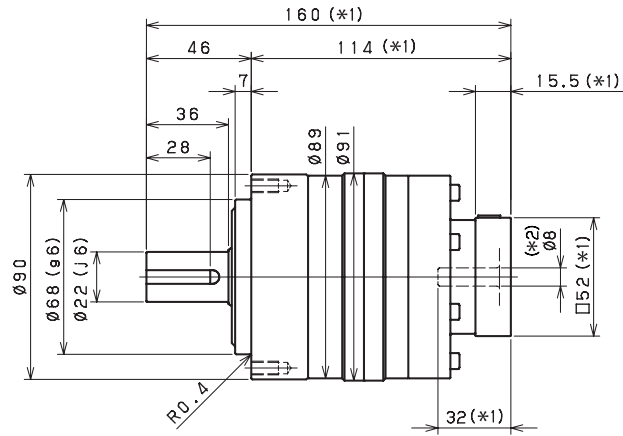
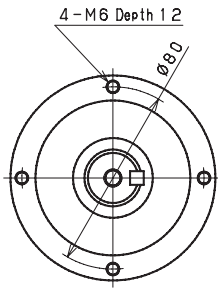

Input bore size  $\leq \varnothing 14$  mm

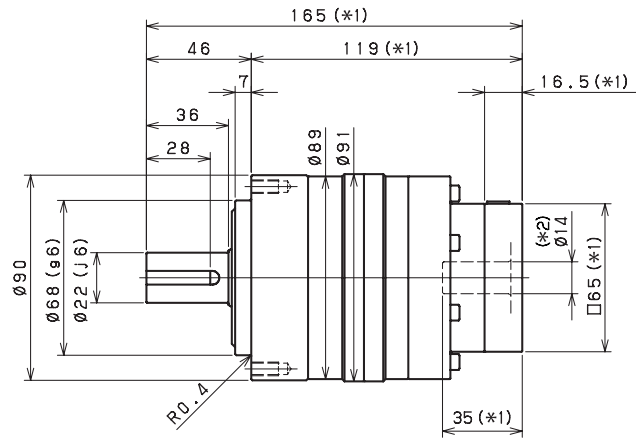
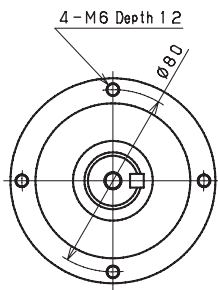

Input bore size  $\leq \varnothing 19$  mm

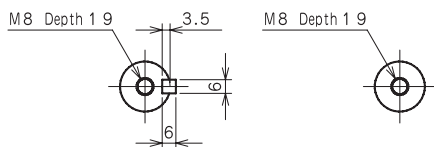
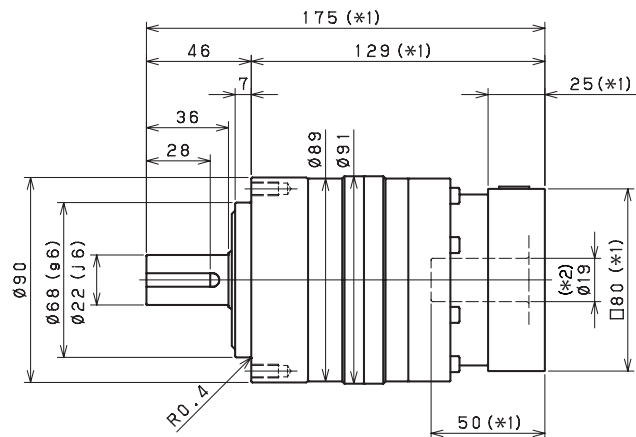
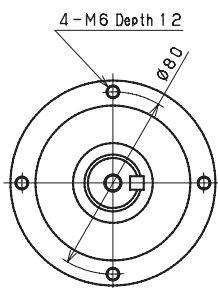

Keyed shaft

Smooth shaft

\*1) Length will vary depending on motor

\*2) Bushing will be inserted to adapt to motor shaft



# VRL SERIES Inline Planetary

## VRL 120 1-Stage Specifications

Frame Size	120									
Stage	1-Stage									
Ratio	Unit	Note	3	4	5	6	7	8	9	10
Nominal Output Torque	[Nm]	*1	120	120	180	180	180	180	120	120
Maximum Output Torque	[Nm]	*2	225	330	330	330	330	330	225	225
Emergency Stop Torque	[Nm]	*3	500	625	625	625	625	625	500	500
Nominal Input Speed	[rpm]	*4	3000							
Maximum Input Speed	[rpm]	*5	6000							
No Load Running Torque	[Nm]	*14	1.30							
Permitted Radial Load	[N]	*6	1300	1500	1600	1700	1800	1900	1900	2000
Permitted Axial Load	[N]	*7	1500	1700	1900	2000	2100	2300	2400	2500
Maximum Radial Load	[N]	*8	4300							
Maximum Axial Load	[N]	*9	3900							
Moment of Inertia ( $\leq \varnothing 14$ )	[kgcm <sup>2</sup> ]		--	--	--	--	--	--	--	--
Moment of Inertia ( $\leq \varnothing 19$ )	[kgcm <sup>2</sup> ]		3.300	2.000	1.600	1.300	1.100	1.000	0.980	0.950
Moment of Inertia ( $\leq \varnothing 28$ )	[kgcm <sup>2</sup> ]		5.300	4.100	3.600	3.300	3.200	3.100	3.000	3.000
Moment of Inertia ( $\leq \varnothing 38$ )	[kgcm <sup>2</sup> ]		13.000	12.000	11.000	11.000	11.000	11.000	11.000	11.000
Efficiency	[%]	*11	95							
Torsional Rigidity	[Nm/arc-min]	*12	31							
Maximum Torsional Backlash	[arc-min]	--	$\leq 5$							
Noise Level	dB [A]	*13	$\leq 71$							
Protection Class		*15	IP54 (IP65)							
Ambient Temperature	[°C]		0-40							
Permitted Housing Temperature	[°C]	*16	90							
Weight	[kg]	*10	7.8							

## VRL 120 2-Stage Specifications

Frame Size	120									
Stage	2-Stage									
Ratio	Unit	Note	15	16	20	25	28	30	35	40
Nominal Output Torque	[Nm]	*1	120	180	180	180	180	120	180	180
Maximum Output Torque	[Nm]	*2	225	330	330	330	330	225	330	330
Emergency Stop Torque	[Nm]	*3	500	625	625	625	625	500	625	625
Nominal Input Speed	[rpm]	*4	3000							
Maximum Input Speed	[rpm]	*5	6000							
No Load Running Torque	[Nm]	*14	0.42							
Permitted Radial Load	[N]	*6	2300	2300	2500	2700	2800	2900	3000	3200
Permitted Axial Load	[N]	*7	3000	3100	3400	3700	3900	3900	3900	3900
Maximum Radial Load	[N]	*8	4300							
Maximum Axial Load	[N]	*9	3900							
Moment of Inertia ( $\leq \varnothing 14$ )	[kgcm <sup>2</sup> ]		0.430	0.480	0.400	0.380	0.440	0.290	0.370	0.280
Moment of Inertia ( $\leq \varnothing 19$ )	[kgcm <sup>2</sup> ]		0.860	0.920	0.830	0.820	0.880	0.740	0.810	0.730
Moment of Inertia ( $\leq \varnothing 28$ )	[kgcm <sup>2</sup> ]		2.800	2.900	2.800	2.800	2.800	2.700	2.700	2.700
Moment of Inertia ( $\leq \varnothing 38$ )	[kgcm <sup>2</sup> ]		--	--	--	--	--	--	--	--
Efficiency	[%]	*11	90							
Torsional Rigidity	[Nm/arc-min]	*12	31							
Maximum Torsional Backlash	[arc-min]	--	$\leq 5$							
Noise Level	dB [A]	*13	$\leq 71$							
Protection Class		*15	IP54 (IP65)							
Ambient Temperature	[°C]		0-40							
Permitted Housing Temperature	[°C]	*16	90							
Weight	[kg]	*10	8.7							

## VRL 120 2-Stage Specifications

Frame Size	120										
Stage	2-Stage										
Ratio	Unit	Note	45	50	60	70	80	90	100		
Nominal Output Torque	[Nm]	*1	120	180	180	180	180	120	120		
Maximum Output Torque	[Nm]	*2	225	330	330	330	330	225	225		
Emergency Stop Torque	[Nm]	*3	500	625	625	625	625	500	500		
Nominal Input Speed	[rpm]	*4	3000								
Maximum Input Speed	[rpm]	*5	6000								
No Load Running Torque	[Nm]	*14	0.42								
Permitted Radial Load	[N]	*6	3300	3400	3600	3800	4000	4200	4300		
Permitted Axial Load	[N]	*7	3900	3900	3900	3900	3900	3900	3900		
Maximum Radial Load	[N]	*8	4300								
Maximum Axial Load	[N]	*9	3900								
Moment of Inertia ( $\leq \varnothing 14$ )	[kgcm <sup>2</sup> ]		0.370	0.280	0.280	0.280	0.280	0.270	0.270		
Moment of Inertia ( $\leq \varnothing 19$ )	[kgcm <sup>2</sup> ]		0.800	0.730	0.730	0.730	0.730	0.730	0.730		
Moment of Inertia ( $\leq \varnothing 28$ )	[kgcm <sup>2</sup> ]		2.700	2.700	2.700	2.700	2.700	2.700	2.700		
Moment of Inertia ( $\leq \varnothing 38$ )	[kgcm <sup>2</sup> ]		--	--	--	--	--	--	--		
Efficiency	[%]	*11	90								
Torsional Rigidity	[Nm/arc-min]	*12	31								
Maximum Torsional Backlash	[arc-min]	--	$\leq 5$								
Noise Level	dB [A]	*13	$\leq 71$								
Protection Class		*15	IP54 (IP65)								
Ambient Temperature	[°C]		0-40								
Permitted Housing Temperature	[°C]	*16	90								
Weight	[kg]	*10	8.7								

- \*1) At nominal input speed, service life is 20,000 hours
- \*2) The maximum torque when starting or stopping operation
- \*3) The maximum torque allowed under a stress situation (Permitted 1,000 times during service life)
- \*4) The average input speed
- \*5) The maximum intermittent input speed
- \*6) Torque at no load applied to the input shaft at nominal input speed
- \*7) At this load and nominal input speed, service life will be 20,000 hours. (The radial load applied to the output side shaft center)
- \*8) At this load and nominal input speed, service life will be 20,000 hours. (The axial load applied to the output side bearing)
- \*9) The maximum radial load that the gearbox can accept
- \*10) The maximum axial load that the gearbox can accept
- \*11) The efficiency at the nominal output torque rating
- \*12) This does not include lost motion
- \*13) Contact NIDEC-SHIMPO for the testing conditions and environment
- \*14) IP65 (wash-down) is available as an option. Contact NIDEC-SHIMPO for more details
- \*15) The weight may vary slightly between models

# VRL SERIES Inline Planetary

## VRL 120 1-Stage Dimensions

Input bore size  $\leq \phi 19$  mm

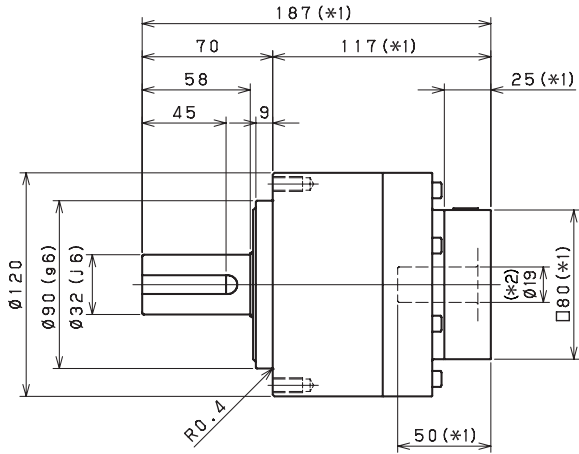
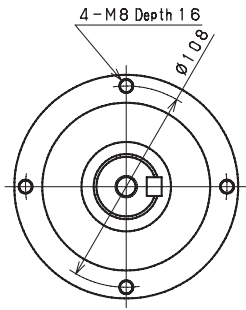

Input bore size  $\leq \phi 28$  mm

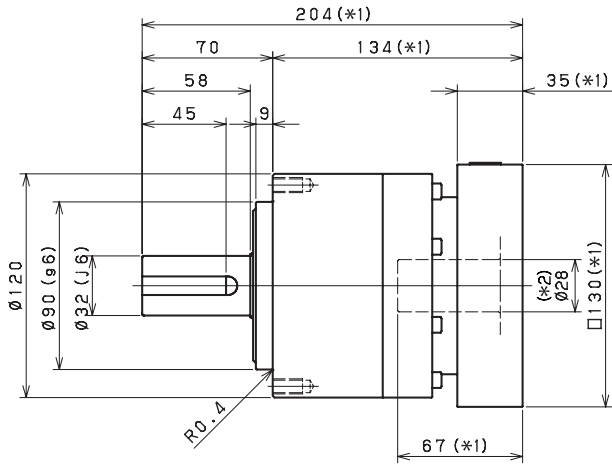
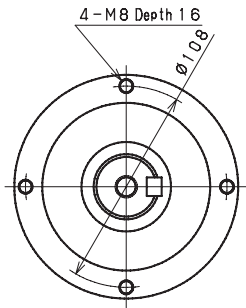

Input bore size  $\leq \phi 38$  mm

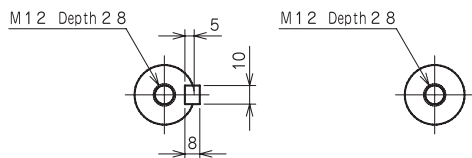
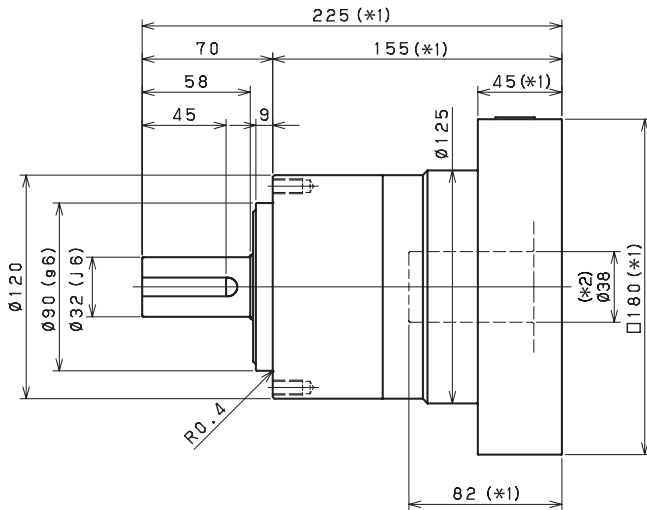
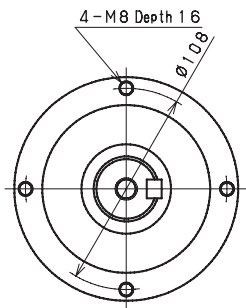

Keyed shaft

Smooth shaft

\*1) Length will vary depending on motor

\*2) Bushing will be inserted to adapt to motor shaft

## VRL 120 2-Stage Dimensions

Input bore size  $\leq \varnothing 14$  mm

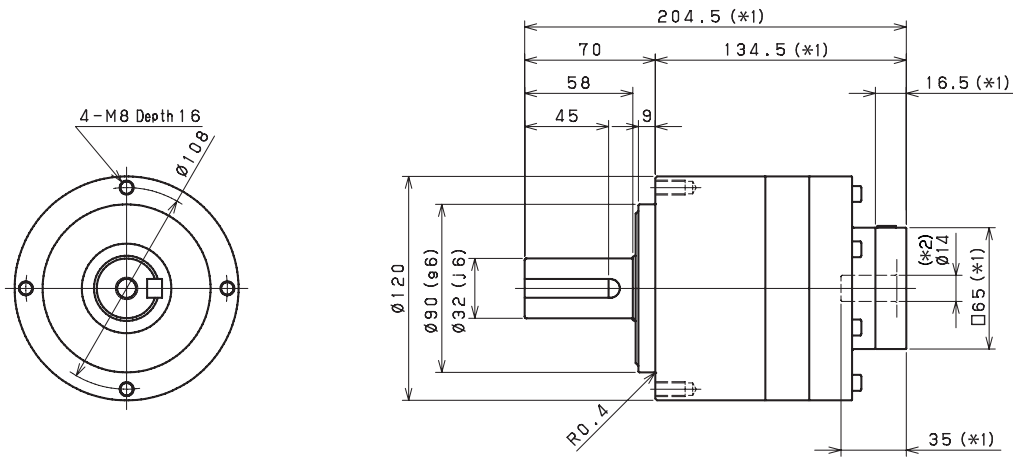

Input bore size  $\leq \varnothing 19$  mm

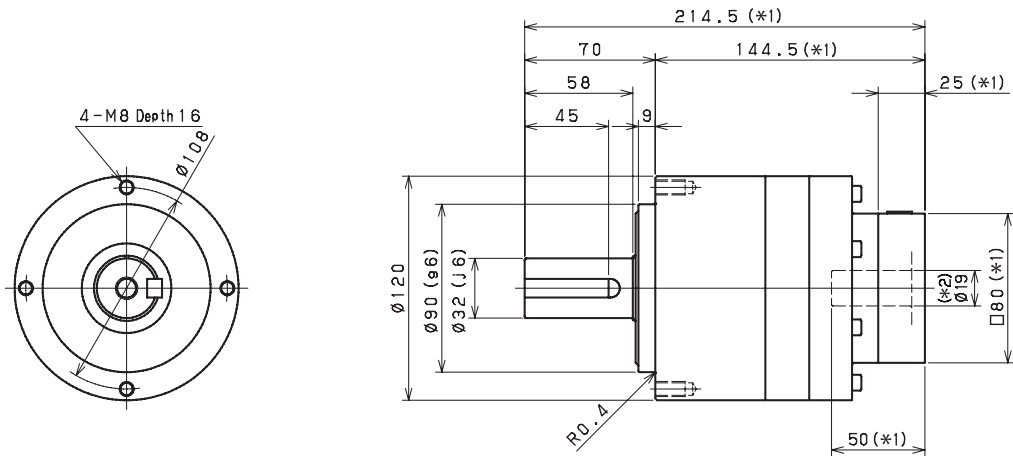

Input bore size  $\leq \varnothing 28$  mm

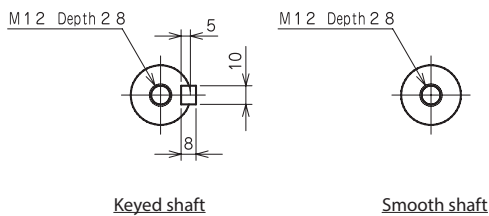
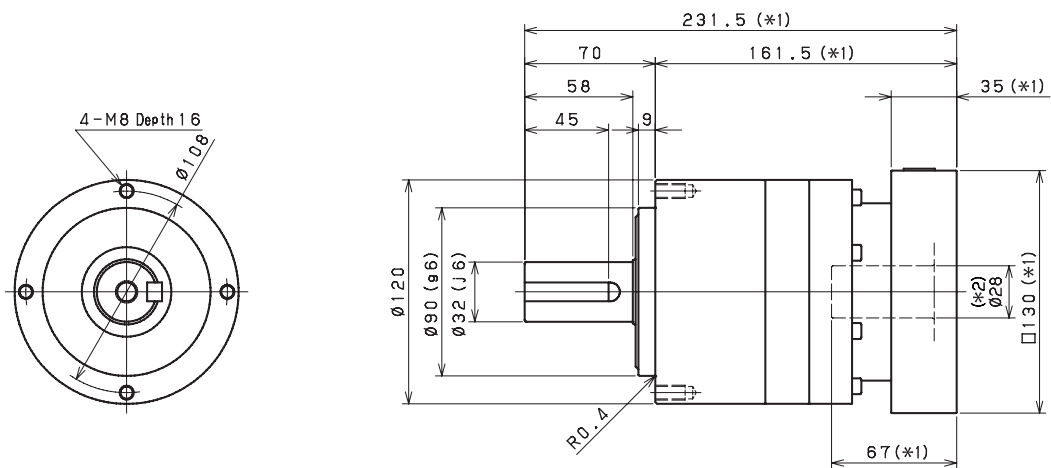

- \*1) Length will vary depending on motor
- \*2) Bushing will be inserted to adapt to motor shaft

# VRL SERIES Inline Planetary

## VRL 155 1-Stage Specifications

Frame Size	155									
Stage	1-Stage									
Ratio	Unit	Note	3	4	5	6	7	8	9	10
Nominal Output Torque	[Nm]	*1	240	240	360	360	360	360	240	240
Maximum Acceleration Torque	[Nm]	*2	470	700	700	700	700	700	470	470
Emergency Stop Torque	[Nm]	*3	1000	1250	1250	1250	1250	1250	1000	1000
Nominal Input Speed	[rpm]	*4	2000							
Maximum Input Speed	[rpm]	*5	4000							
No Load Running Torque	[Nm]	*6	1.63							
Permitted Radial Load	[N]	*7	3200	3500	3800	4000	4200	4400	4600	4700
Permitted Axial Load	[N]	*8	2400	2700	3000	3300	3500	3700	3900	4100
Maximum Radial Load	[N]	*9	9100							
Maximum Axial Load	[N]	*10	8200							
Moment of Inertia ( $\leq \varnothing 19$ )	[kgcm <sup>2</sup> ]	--	--	--	--	--	--	--	--	--
Moment of Inertia ( $\leq \varnothing 28$ )	[kgcm <sup>2</sup> ]	--	12.000	7.500	5.800	4.900	4.100	3.800	3.600	3.500
Moment of Inertia ( $\leq \varnothing 38$ )	[kgcm <sup>2</sup> ]	--	20.000	15.000	14.000	13.000	12.000	12.000	11.000	11.000
Moment of Inertia ( $\leq \varnothing 48$ )	[kgcm <sup>2</sup> ]	--	42.000	37.000	36.000	35.000	34.000	34.000	34.000	34.000
Efficiency	[%]	*11	95							
Torsional Rigidity	[Nm/arc-min]	*12	60							
Maximum Torsional Backlash	[arc-min]	--	$\leq 5$							
Noise Level	dB [A]	*13	$\leq 67$							
Protection Class	--	*14	IP54 (IP65)							
Ambient Temperature	[°C]	--	0-40							
Permitted Housing Temperature	[°C]	--	90							
Weight	[kg]	*15	16							

## VRL 155 2-Stage Specifications

Frame Size	155									
Stage	2-Stage									
Ratio	Unit	Note	15	16	20	25	28	30	35	40
Nominal Output Torque	[Nm]	*1	240	360	360	360	360	240	360	360
Maximum Acceleration Torque	[Nm]	*2	470	700	700	700	700	470	700	700
Emergency Stop Torque	[Nm]	*3	1000	1250	1250	1250	1250	1000	1250	1250
Nominal Input Speed	[rpm]	*4	2000							
Maximum Input Speed	[rpm]	*5	4000							
No Load Running Torque	[Nm]	*6	0.56							
Permitted Radial Load	[N]	*7	5400	5500	6000	6400	6700	6800	7200	7500
Permitted Axial Load	[N]	*8	4900	5000	5500	6100	6400	6600	7000	7500
Maximum Radial Load	[N]	*9	9100							
Maximum Axial Load	[N]	*10	8200							
Moment of Inertia ( $\leq \varnothing 19$ )	[kgcm <sup>2</sup> ]	--	1.300	1.500	1.200	1.100	1.400	0.850	1.100	0.830
Moment of Inertia ( $\leq \varnothing 28$ )	[kgcm <sup>2</sup> ]	--	3.200	3.500	3.100	3.100	3.300	2.800	3.100	2.800
Moment of Inertia ( $\leq \varnothing 38$ )	[kgcm <sup>2</sup> ]	--	11.000	11.000	11.000	11.000	11.000	10.000	11.000	10.000
Moment of Inertia ( $\leq \varnothing 48$ )	[kgcm <sup>2</sup> ]	--	--	--	--	--	--	--	--	--
Efficiency	[%]	*11	90							
Torsional Rigidity	[Nm/arc-min]	*12	60							
Maximum Torsional Backlash	[arc-min]	--	$\leq 5$							
Noise Level	dB [A]	*13	$\leq 67$							
Protection Class	--	*14	IP54 (IP65)							
Ambient Temperature	[°C]	--	0-40							
Permitted Housing Temperature	[°C]	--	90							
Weight	[kg]	*15	18							

## VRL 155 2-Stage Specifications

Frame Size	155										
Stage	2-Stage										
Ratio	Unit	Note	45	50	60	70	80	90	100		
Nominal Output Torque	[Nm]	*1	240	360	360	360	360	240	240		
Maximum Acceleration Torque	[Nm]	*2	470	700	700	700	700	470	470		
Emergency Stop Torque	[Nm]	*3	1000	1250	1250	1250	1250	1000	1000		
Nominal Input Speed	[rpm]	*4	2000								
Maximum Input Speed	[rpm]	*5	4000								
No Load Running Torque	[Nm]	*6	0.56								
Permitted Radial Load	[N]	*7	7800	8100	8600	9100	9100	9100	9100		
Permitted Axial Load	[N]	*8	7900	8200	8200	8200	8200	8200	8200		
Maximum Radial Load	[N]	*9	9100								
Maximum Axial Load	[N]	*10	8200								
Moment of Inertia (≤Ø 19)	[kgcm <sup>2</sup> ]	--	1.100	0.810	0.810	0.800	0.800	0.800	0.800		
Moment of Inertia (≤ Ø 28)	[kgcm <sup>2</sup> ]	--	3.000	2.800	2.800	2.800	2.800	2.800	2.800		
Moment of Inertia (≤ Ø 38)	[kgcm <sup>2</sup> ]	--	11.000	10.000	10.000	10.000	10.000	10.000	10.000		
Moment of Inertia (≤ Ø 48)	[kgcm <sup>2</sup> ]	--	--	--	--	--	--	--	--		
Efficiency	[%]	*11	90								
Torsional Rigidity	[Nm/arc-min]	*12	60								
Maximum Torsional Backlash	[arc-min]	--	≤ 5								
Noise Level	dB [A]	*13	≤ 67								
Protection Class	--	*14	IP54 (IP65)								
Ambient Temperature	[°C]	--	0-40								
Permitted Housing Temperature	[°C]	--	90								
Weight	[kg]	*15	18								

- \*1) At nominal input speed, service life is 20,000 hours
- \*2) The maximum torque when starting or stopping operation
- \*3) The maximum torque allowed under a stress situation (Permitted 1,000 times during service life)
- \*4) The average input speed
- \*5) The maximum intermittent input speed
- \*6) Torque at no load applied to the input shaft at nominal input speed
- \*7) At this load and nominal input speed, service life will be 20,000 hours. (The radial load applied to the output side shaft center)
- \*8) At this load and nominal input speed, service life will be 20,000 hours. (The axial load applied to the output side bearing)
- \*9) The maximum radial load that the gearbox can accept
- \*10) The maximum axial load that the gearbox can accept
- \*11) The efficiency at the nominal output torque rating
- \*12) This does not include lost motion
- \*13) Contact NIDEC-SHIMPO for the testing conditions and environment
- \*14) IP65 (wash-down) is available as an option. Contact NIDEC-SHIMPO for more details
- \*15) The weight may vary slightly between models

# VRL SERIES Inline Planetary

## VRL 155 1-Stage Dimensions

Input bore size  $\leq \phi 28$  mm

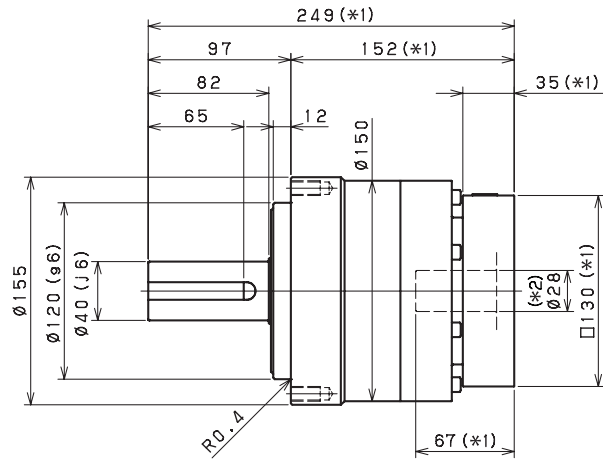
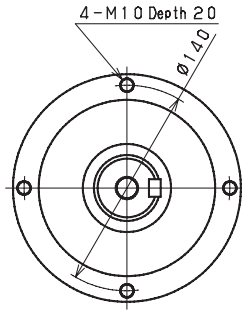

Input bore size  $\leq \phi 38$  mm

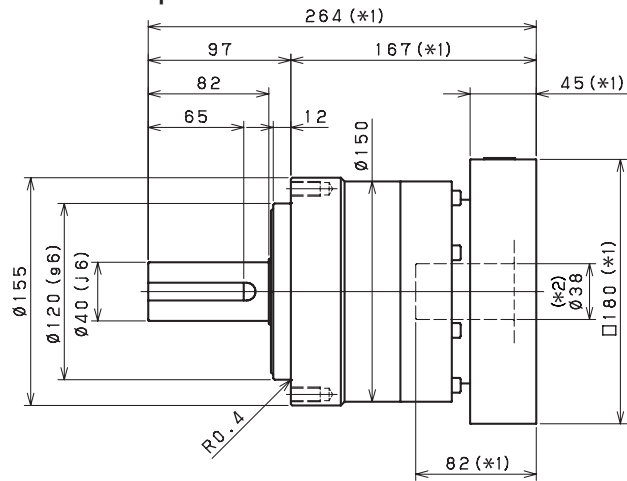
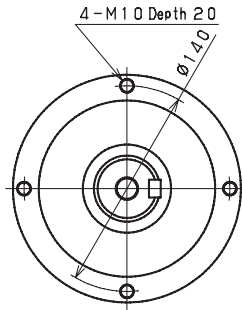

Input bore size  $\leq \phi 48$  mm

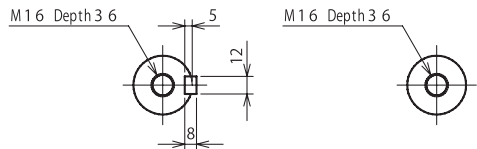
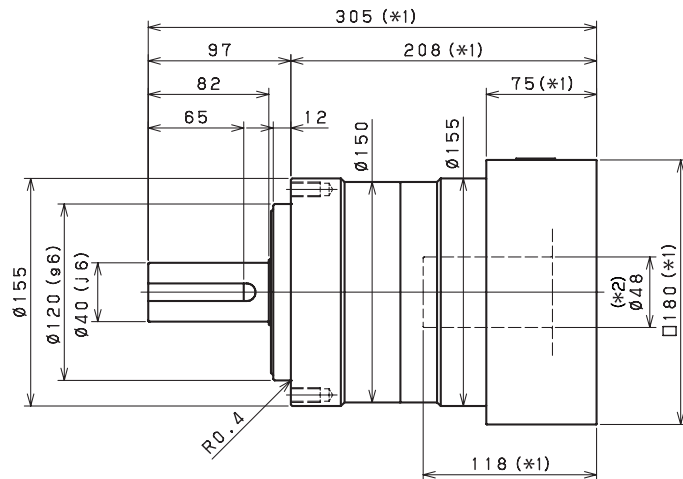
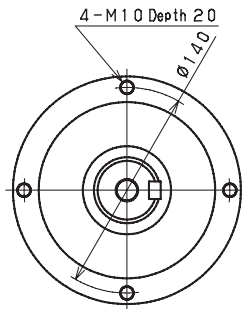

Keyed shaft

Smooth shaft

\*1) Length will vary depending on motor

\*2) Bushing will be inserted to adapt to motor shaft

## VRL 155 2-Stage Dimensions

Input bore size  $\leq \phi 19$  mm

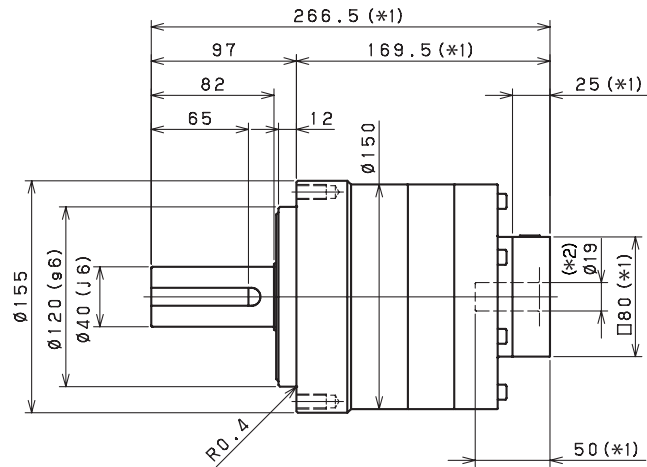
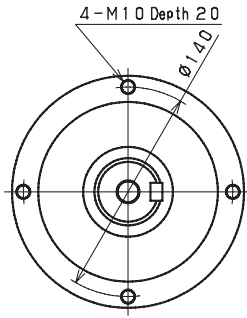

Input bore size  $\leq \phi 28$  mm

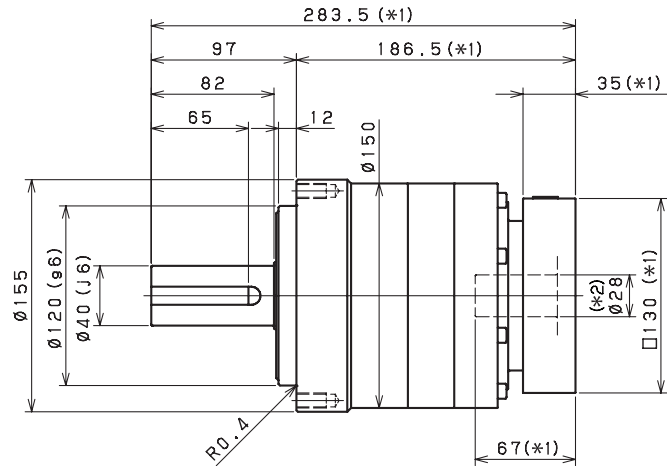
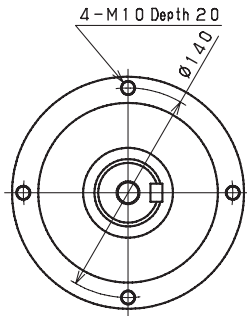

Input bore size  $\leq \phi 38$  mm

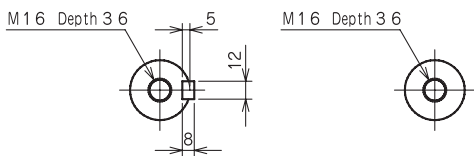
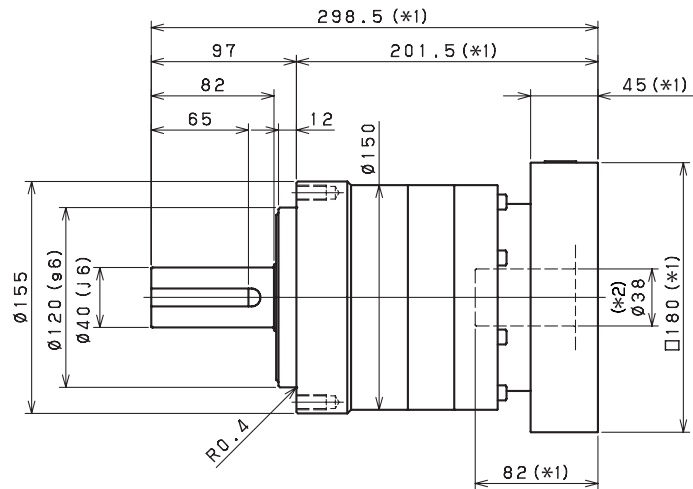
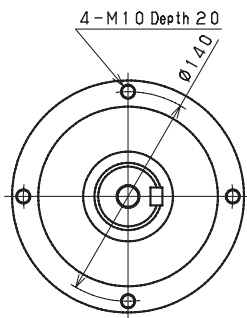

Keyed shaft

Smooth shaft

\*1) Length will vary depending on motor

\*2) Bushing will be inserted to adapt to motor shaft



# VRL SERIES Inline Planetary

## VRL 205 1-Stage Specifications

Frame Size	205									
Stage	1-Stage									
Ratio	Unit	Note	3	4	5	6	7	8	9	10
Nominal Output Torque	[Nm]	*1	500	750	750	750	750	750	500	500
Maximum Acceleration Torque	[Nm]	*2	970	1400	1400	1400	1400	1400	970	970
Emergency Stop Torque	[Nm]	*3	2200	2750	2750	2750	2750	2750	2200	2200
Nominal Input Speed	[rpm]	*4	1500							
Maximum Input Speed	[rpm]	*5	3000							
No Load Running Torque	[Nm]	*6	2.68							
Permitted Radial Load	[N]	*7	5600	6200	6700	7100	7400	7800	8100	8400
Permitted Axial Load	[N]	*8	4300	4900	5400	5800	6300	6600	7000	7300
Maximum Radial Load	[N]	*9	15000							
Maximum Axial Load	[N]	*10	14000							
Moment of Inertia ( $\leq \varnothing 28$ )	[kgcm <sup>2</sup> ]	--	--	--	--	--	--	--	--	--
Moment of Inertia ( $\leq \varnothing 38$ )	[kgcm <sup>2</sup> ]	--	44.000	28.000	22.000	18.000	16.000	15.000	14.000	14.000
Moment of Inertia ( $\leq \varnothing 48$ )	[kgcm <sup>2</sup> ]	--	66.000	50.000	44.000	41.000	38.000	37.000	36.000	36.000
Moment of Inertia ( $\leq \varnothing 65$ )	[kgcm <sup>2</sup> ]	--	130.000	110.000	100.000	100.000	99.000	97.000	97.000	96.000
Efficiency	[%]	*11	95							
Torsional Rigidity	[Nm/arc-min]	*12	175							
Maximum Torsional Backlash	[arc-min]	--	$\leq 5$							
Noise Level	dB [A]	*13	$\leq 67$							
Protection Class	--	*14	IP54 (IP65)							
Ambient Temperature	[°C]	--	0-40							
Permitted Housing Temperature	[°C]	--	90							
Weight	[kg]	*15	39							

## VRL 205 2-Stage Specifications

Frame Size	205									
Stage	2-Stage									
Ratio	Unit	Note	15	16	20	25	28	30	35	40
Nominal Output Torque	[Nm]	*1	500	750	750	750	750	500	750	750
Maximum Acceleration Torque	[Nm]	*2	970	1400	1400	1400	1400	970	1400	1400
Emergency Stop Torque	[Nm]	*3	2200	2750	2750	2750	2750	2200	2750	2750
Nominal Input Speed	[rpm]	*4	1500							
Maximum Input Speed	[rpm]	*5	3000							
No Load Running Torque	[Nm]	*6	1.39							
Permitted Radial Load	[N]	*7	9600	9800	11000	11000	12000	12000	13000	13000
Permitted Axial Load	[N]	*8	8700	8900	9900	11000	11000	12000	13000	13000
Maximum Radial Load	[N]	*9	15000							
Maximum Axial Load	[N]	*10	14000							
Moment of Inertia ( $\leq \varnothing 28$ )	[kgcm <sup>2</sup> ]	--	4.700	5.400	4.400	4.200	4.900	3.200	4.100	3.200
Moment of Inertia ( $\leq \varnothing 38$ )	[kgcm <sup>2</sup> ]	--	12.000	13.000	12.000	12.000	13.000	11.000	12.000	11.000
Moment of Inertia ( $\leq \varnothing 48$ )	[kgcm <sup>2</sup> ]	--	34.000	35.000	34.000	34.000	35.000	33.000	34.000	33.000
Moment of Inertia ( $\leq \varnothing 65$ )	[kgcm <sup>2</sup> ]	--	--	--	--	--	--	--	--	--
Efficiency	[%]	*11	90							
Torsional Rigidity	[Nm/arc-min]	*12	175							
Maximum Torsional Backlash	[arc-min]	--	$\leq 5$							
Noise Level	dB [A]	*13	$\leq 67$							
Protection Class	--	*14	IP54 (IP65)							
Ambient Temperature	[°C]	--	0-40							
Permitted Housing Temperature	[°C]	--	90							
Weight	[kg]	*15	40							

## VRL 205 2-Stage Specifications

Frame Size	205										
Stage	2-Stage										
Ratio	Unit	Note	45	50	60	70	80	90	100		
Nominal Output Torque	[Nm]	*1	500	750	750	750	750	500	500		
Maximum Acceleration Torque	[Nm]	*2	970	1400	1400	1400	1400	970	970		
Emergency Stop Torque	[Nm]	*3	2200	2750	2750	2750	2750	2200	2200		
Nominal Input Speed	[rpm]	*4	1500								
Maximum Input Speed	[rpm]	*5	3000								
No Load Running Torque	[Nm]	*6	1.39								
Permitted Radial Load	[N]	*7	14000	14000	15000	15000	15000	15000	15000		
Permitted Axial Load	[N]	*8	14000	14000	14000	14000	14000	14000	14000		
Maximum Radial Load	[N]	*9	15000								
Maximum Axial Load	[N]	*10	14000								
Moment of Inertia (≤Ø 28)	[kgcm <sup>2</sup> ]	--	4.000	3.100	3.100	3.100	3.100	3.100	3.100		
Moment of Inertia (≤ Ø 38)	[kgcm <sup>2</sup> ]	--	12.000	11.000	11.000	11.000	11.000	11.000	11.000		
Moment of Inertia (≤ Ø 48)	[kgcm <sup>2</sup> ]	--	34.000	33.000	33.000	33.000	33.000	33.000	33.000		
Moment of Inertia (≤ Ø 65)	[kgcm <sup>2</sup> ]	--	--	--	--	--	--	--	--		
Efficiency	[%]	*11	90								
Torsional Rigidity	[Nm/arc-min]	*12	175								
Maximum Torsional Backlash	[arc-min]	--	≤ 5								
Noise Level	dB [A]	*13	≤ 67								
Protection Class	--	*14	IP54 (IP65)								
Ambient Temperature	[°C]	--	0-40								
Permitted Housing Temperature	[°C]	--	90								
Weight	[kg]	*15	40								

- \*1) At nominal input speed, service life is 20,000 hours
- \*2) The maximum torque when starting or stopping operation
- \*3) The maximum torque allowed under a stress situation (Permitted 1,000 times during service life)
- \*4) The average input speed
- \*5) The maximum intermittent input speed
- \*6) Torque at no load applied to the input shaft at nominal input speed
- \*7) At this load and nominal input speed, service life will be 20,000 hours. (The radial load applied to the output side shaft center)
- \*8) At this load and nominal input speed, service life will be 20,000 hours. (The axial load applied to the output side bearing)
- \*9) The maximum radial load that the gearbox can accept
- \*10) The maximum axial load that the gearbox can accept
- \*11) The efficiency at the nominal output torque rating
- \*12) This does not include lost motion
- \*13) Contact NIDEC-SHIMPO for the testing conditions and environment
- \*14) IP65 (wash-down) is available as an option. Contact NIDEC-SHIMPO for more details
- \*15) The weight may vary slightly between models

# VRL SERIES Inline Planetary

## VRL 205 1-Stage Dimensions

Input bore size  $\leq \phi 38$  mm

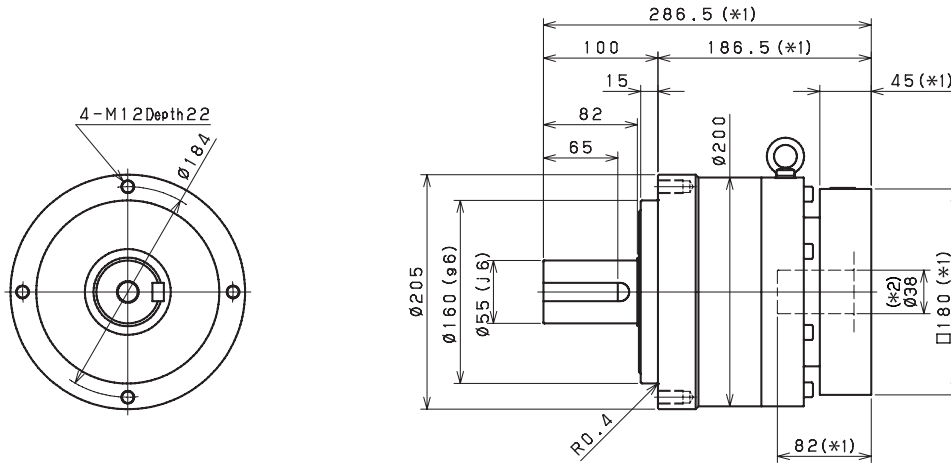

Input bore size  $\leq \phi 48$  mm

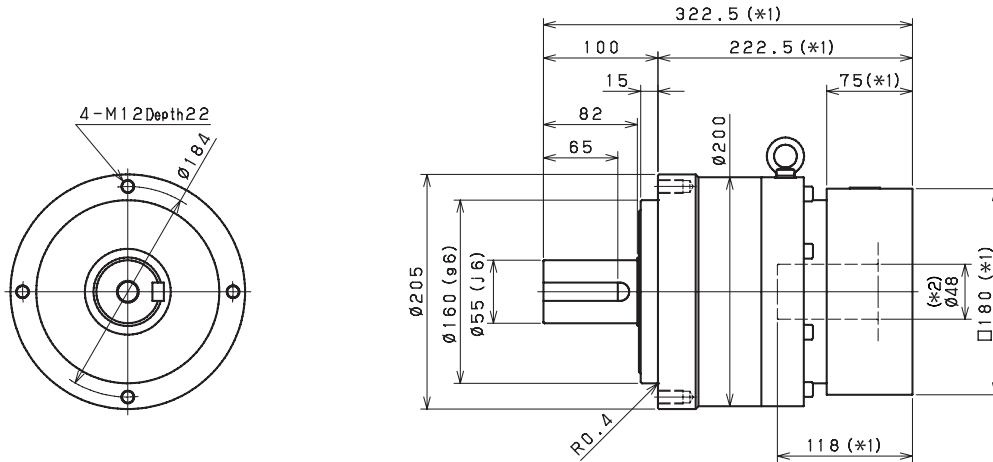

Input bore size  $\leq \phi 65$  mm

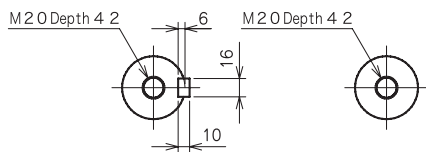
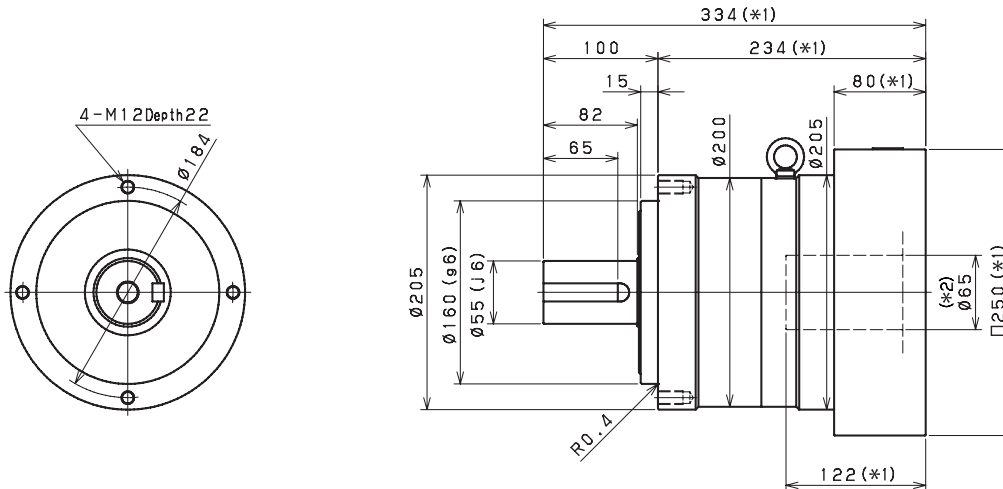

Keyed shaft

Smooth shaft

\*1) Length will vary depending on motor

\*2) Bushing will be inserted to adapt to motor shaft

## VRL 205 2-Stage Dimensions

Input bore size  $\leq \varnothing 28$  mm

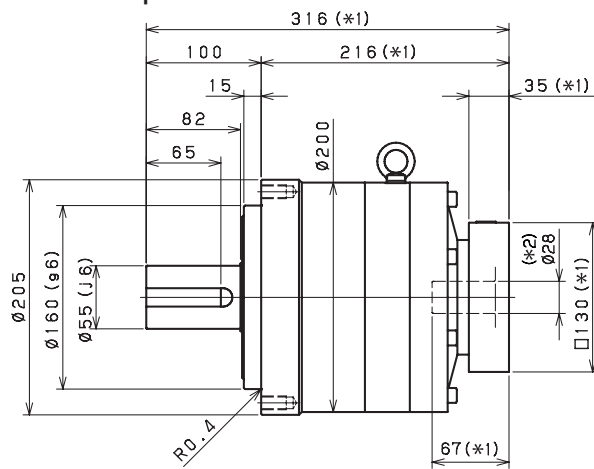
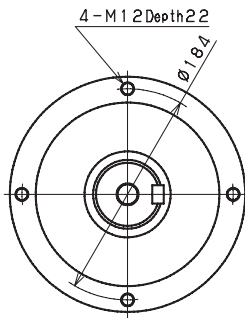

Input bore size  $\leq \varnothing 38$  mm

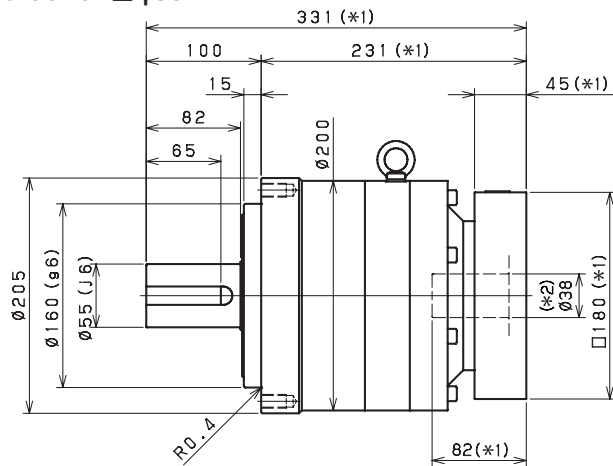
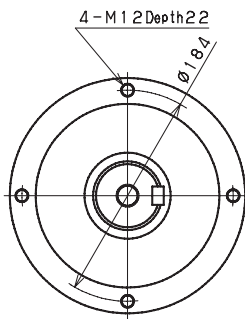

Input bore size  $\leq \varnothing 48$  mm

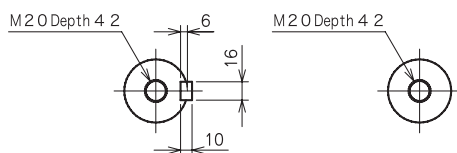
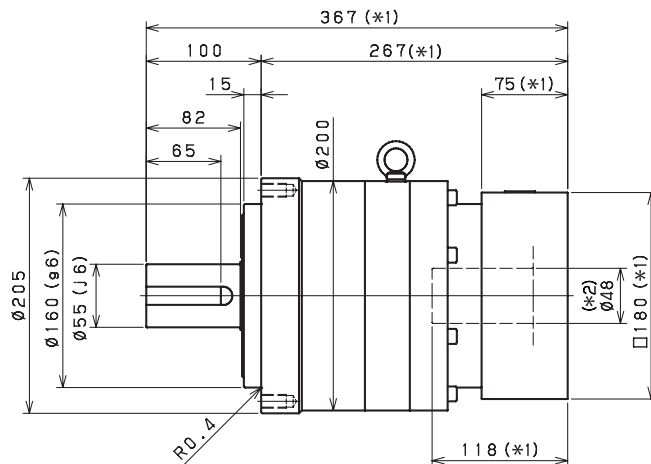
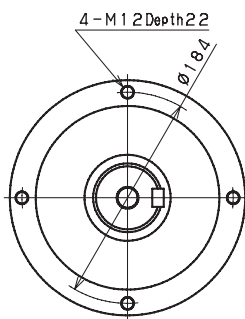

Keyed shaft

Smooth shaft

\*1) Length will vary depending on motor

\*2) Bushing will be inserted to adapt to motor shaft

# VRL SERIES Inline Planetary

## VRL 235 1-Stage Specifications

Frame Size	235									
Stage	1-Stage									
Ratio	Unit	Note	3	4	5	6	7	8	9	10
Nominal Output Torque	[Nm]	*1	1000	1500	1500	1500	1500	1500	1000	1000
Maximum Acceleration Torque	[Nm]	*2	1600	2300	2300	2300	2300	2200	1900	1600
Emergency Stop Torque	[Nm]	*3	4000	5000	5000	5000	5000	5000	4000	4000
Nominal Input Speed	[rpm]	*4	1000							
Maximum Input Speed	[rpm]	*5	2000							
No Load Running Torque	[Nm]	*6	2.92							
Permitted Radial Load	[N]	*7	5800	6400	6900	7300	7700	8000	8400	8700
Permitted Axial Load	[N]	*8	6400	7200	7900	8600	9200	9700	10000	11000
Maximum Radial Load	[N]	*9	15000							
Maximum Axial Load	[N]	*10	14000							
Moment of Inertia ( $\leq \varnothing 38$ )	[kgcm <sup>2</sup> ]	--	--	--	--	--	--	--	--	--
Moment of Inertia ( $\leq \varnothing 48$ )	[kgcm <sup>2</sup> ]	--	90.000	62.000	52.000	47.000	42.000	40.000	39.000	38.000
Moment of Inertia ( $\leq \varnothing 65$ )	[kgcm <sup>2</sup> ]	--	150.000	120.000	110.000	110.000	100.000	100.000	99.000	98.000
Efficiency	[%]	*11	97							
Torsional Rigidity	[Nm/arc-min]	*12	400							
Maximum Torsional Backlash	[arc-min]	--	$\leq 5$							
Noise Level	dB [A]	*13	$\leq 61$							
Protection Class	--	*14	IP54 (IP65)							
Ambient Temperature	[°C]	--	0-40							
Permitted Housing Temperature	[°C]	--	90							
Weight	[kg]	*15	55							

## VRL 235 2-Stage Specifications

Frame Size	235									
Stage	2-Stage									
Ratio	Unit	Note	15	16	20	25	28	30	35	40
Nominal Output Torque	[Nm]	*1	1000	1500	1500	1500	1500	1000	1500	1500
Maximum Acceleration Torque	[Nm]	*2	1600	2300	2300	2300	2300	1600	2300	2300
Emergency Stop Torque	[Nm]	*3	4000	5000	5000	5000	5000	4000	5000	5000
Nominal Input Speed	[rpm]	*4	1000							
Maximum Input Speed	[rpm]	*5	2000							
No Load Running Torque	[Nm]	*6	1.14							
Permitted Radial Load	[N]	*7	9900	10000	11000	12000	12000	13000	13000	14000
Permitted Axial Load	[N]	*8	13000	13000	14000	14000	14000	14000	14000	14000
Maximum Radial Load	[N]	*9	15000							
Maximum Axial Load	[N]	*10	14000							
Moment of Inertia ( $\leq \varnothing 38$ )	[kgcm <sup>2</sup> ]	--	14.000	16.000	14.000	14.000	15.000	12.000	13.000	12.000
Moment of Inertia ( $\leq \varnothing 48$ )	[kgcm <sup>2</sup> ]	--	36.000	37.000	35.000	35.000	36.000	34.000	35.000	33.000
Moment of Inertia ( $\leq \varnothing 65$ )	[kgcm <sup>2</sup> ]	--	--	--	--	--	--	--	--	--
Efficiency	[%]	*11	92							
Torsional Rigidity	[Nm/arc-min]	*12	400							
Maximum Torsional Backlash	[arc-min]	--	$\leq 5$							
Noise Level	dB [A]	*13	$\leq 61$							
Protection Class	--	*14	IP54 (IP65)							
Ambient Temperature	[°C]	--	0-40							
Permitted Housing Temperature	[°C]	--	90							
Weight	[kg]	*15	57							

## VRL 235 2-Stage Specifications

Frame Size	235										
Stage	2-Stage										
Ratio	Unit	Note	45	50	60	70	80	90	100		
Nominal Output Torque	[Nm]	*1	1000	1500	1500	1500	1500	1000	1000		
Maximum Acceleration Torque	[Nm]	*2	1300	2300	2300	2300	1800	1300	1200		
Emergency Stop Torque	[Nm]	*3	4000	5000	5000	5000	5000	4000	4000		
Nominal Input Speed	[rpm]	*4	1000								
Maximum Input Speed	[rpm]	*5	2000								
No Load Running Torque	[Nm]	*6	1.14								
Permitted Radial Load	[N]	*7	14000	15000	15000	15000	15000	15000	15000		
Permitted Axial Load	[N]	*8	14000	14000	14000	14000	14000	14000	14000		
Maximum Radial Load	[N]	*9	15000								
Maximum Axial Load	[N]	*10	14000								
Moment of Inertia (≤ Ø 38)	[kgcm <sup>2</sup> ]	--	13.000	12.000	12.000	12.000	12.000	12.000	12.000		
Moment of Inertia (≤ Ø 48)	[kgcm <sup>2</sup> ]	--	35.000	33.000	33.000	33.000	33.000	33.000	33.000		
Moment of Inertia (≤ Ø 65)	[kgcm <sup>2</sup> ]	--	--	--	--	--	--	--	--		
Efficiency	[%]	*11	92								
Torsional Rigidity	[Nm/arc-min]	*12	400								
Maximum Torsional Backlash	[arc-min]	--	≤ 5								
Noise Level	dB [A]	*13	≤ 61								
Protection Class	--	*14	IP54 (IP65)								
Ambient Temperature	[°C]	--	0-40								
Permitted Housing Temperature	[°C]	--	90								
Weight	[kg]	*15	57								

- \*1) At nominal input speed, service life is 20,000 hours
- \*2) The maximum torque when starting or stopping operation
- \*3) The maximum torque allowed under a stress situation (Permitted 1,000 times during service life)
- \*4) The average input speed
- \*5) The maximum intermittent input speed
- \*6) Torque at no load applied to the input shaft at nominal input speed
- \*7) At this load and nominal input speed, service life will be 20,000 hours. (The radial load applied to the output side shaft center)
- \*8) At this load and nominal input speed, service life will be 20,000 hours. (The axial load applied to the output side bearing)
- \*9) The maximum radial load that the gearbox can accept
- \*10) The maximum axial load that the gearbox can accept
- \*11) The efficiency at the nominal output torque rating
- \*12) This does not include lost motion
- \*13) Contact NIDEC-SHIMPO for the testing conditions and environment
- \*14) IP65 (wash-down) is available as an option. Contact NIDEC-SHIMPO for more details
- \*15) The weight may vary slightly between models



## VRL 235 2-Stage Dimensions

Input bore size  $\leq \varnothing 38$  mm

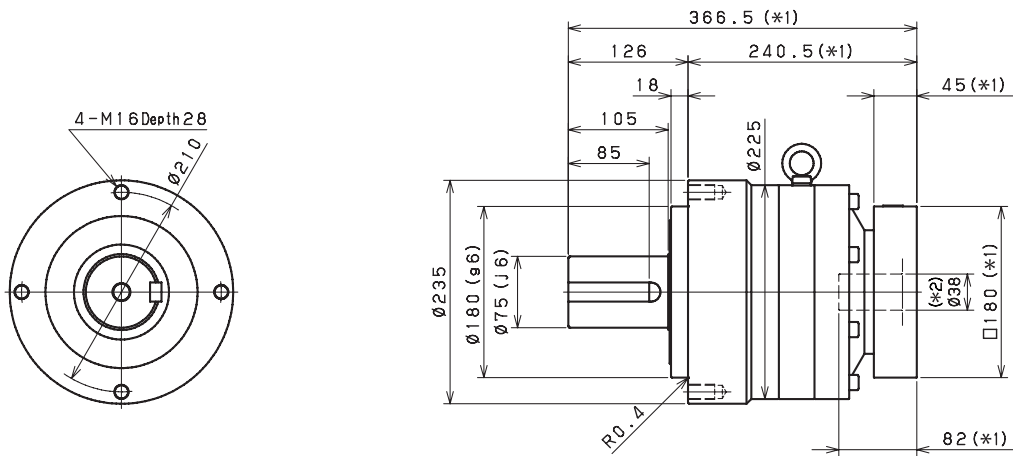

Input bore size  $\leq \varnothing 48$  mm

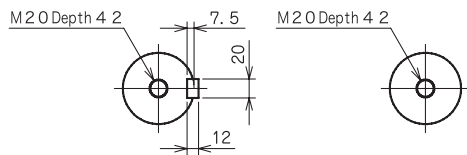
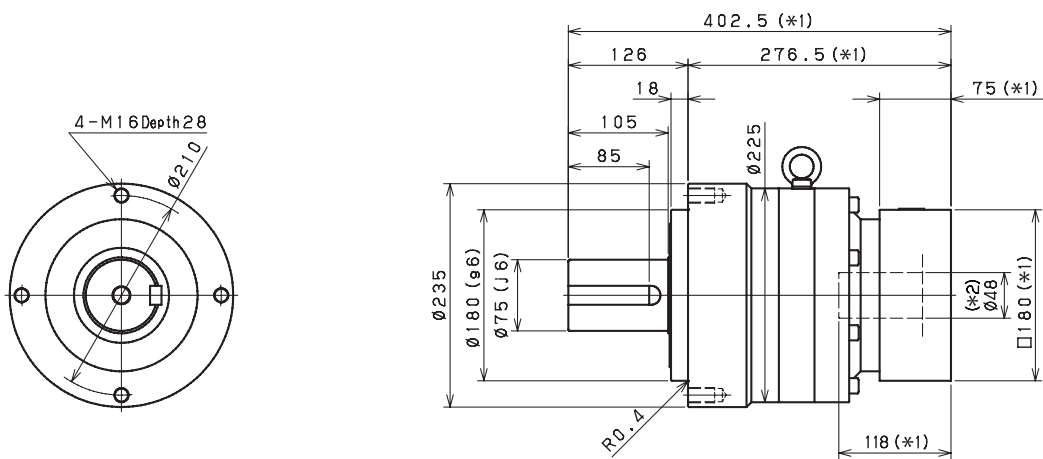

\*1) Length will vary depending on motor

\*2) Bushing will be inserted to adapt to motor shaft