



Automation for a Changing World

# Delta Vector Control Drive C2000 Series



reddot design award  
winner 2010

[www.deltaww.com](http://www.deltaww.com)

 **DELTA**  
Smarter. Greener. Together.



# **Powerful Features. High Efficiency.**

The C2000 Series AC motor drive provides the most efficient solution for all types of drive applications. It features precise speed, torque and position control functions that are suitable for both sensor and sensorless types of synchronous and asynchronous motors. The C2000 Series is also equipped with built-in PLC functions and supports the CANopen Master/Slave extension for the ultimate in system flexibility and fast data exchange.

## Table of Contents

<b>Standard Models</b>	<b>3</b>
<b>Advanced Drive Controls</b>	<b>3</b>
<b>Modular Design</b>	<b>5</b>
<b>Certifications</b>	<b>6</b>
<b>LCD Keypad</b>	<b>7</b>
<b>Features &amp; Applications</b>	<b>8</b>
High-speed networks	
Convenient operation platform	
High performance field oriented control	
Fast response to impact load	
Auto energy saving operation	
DEB function	
Permanent magnet motors (SPM, IPM)	
REG2000 Series	
AFE2000 Series	
<b>Active Front End AFE2000 Series</b>	<b>11</b>
<b>Operation Environment</b>	<b>12</b>
<b>Specifications</b>	<b>13</b>
Wiring	
Dimensions	
Option cards	
Ordering information	

## Standard Models (IP20/NEMA1)

Power range : 230V 0.75 ~ 90kW, 460V 0.75 ~ 450kW

230 V (kW)	0.75	1.5	2.2	3.7	5.5	7.5	11	15	18.5	22	30	37	45	55	75	90
230 V (HP)	1	2	3	5	7.5	10	15	20	25	30	40	50	60	75	100	125
Frame Size	A			B			C			D			E			F

460 V (kW)	0.75	1.5	2.2	3.7	4.0	5.5	7.5	11	15	18.5	22	30	37	45	55	75
460 V (HP)	1	2	3	5	5	7.5	10	15	20	25	30	40	50	60	75	100
Frame Size	A						B			C			D0		D	

Power range: 575V 1.5~15kW

575 V (kW)	1.5	2.2	3.7	5.5	7.5	11	15
575 V (HP)	2	3	5	7.5	10	15	20
Frame Size	A			B			

Power range: 690V 18.5~630kW

690 V (kW)	18.5	22	30	37	45	55	75	90	110	132	160	200	250	315	400	450
690 V (HP)	25	30	40	50	60	75	100	125	150	175	215	270	335	425	530	600
Frame Size	C			D			E			F		G			H	

## Advanced Drive Controls

### High Performance

1. High bandwidth control
2. Speed / torque / position control mode
3. Dual rating design (Normal duty / heavy duty)
4. 4-quadrant torque control and limit
5. For both synchronous and asynchronous motors

### Environmental Adaptability

1. 50°C operating temperature
2. Built-in DC reactor
3. Coated circuit boards
4. Built-in EMC filter
5. International safety standard (CE/UL/cUL)

\*Note: Please refer to the Product Specification



90	110	132	160	185	220	280	315	355	450
125	150	175	215	250	300	375	425	475	600
E		F		G		H			

560	630
745	840

#### ▪ Versatile Drive Controls

1. Built-in safe stop function
2. Built-in PLC function
3. Built-in brake unit
4. Supports various network protocols
5. Position control

#### ▪ Modular Design

1. Hot pluggable LCD keypad
2. I/O extension cards
3. Various PG (encoder) feedback cards
4. Network cards for fieldbus modules
5. Removable fan



# Modular Design

Various accessories options, such as I/O extension cards, encoder feedback cards, communication cards, hot pluggable LCD keypad, removable terminals and removable fans.

## ▶ PG (Encoder) cards

EMC-PG010 / EMC-PG020



EMC-PG01U / EMC-PG02U



EMC-PG01L / EMC-PG02L



EMC-PG01R



## ■ Removable fan

To ensure personal safety, do not begin wiring before the indicator light is off.

## ■ Power indicator

To prevent personal injury, please do not perform wiring before power indicator is off.

## ■ Removable terminals

Convenient wiring and safety equipment.

\*NOTE: "▶" are optional accessories.

## ▶ I/O extension cards

EMC-D611A



EMC-D42A



## ▶ 24V Power Shift Card

EMC-BPS01



## ▶ Relay Extension Card

EMC-R6AA

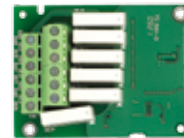

## ▶ Communication cards

CMC-PD01



CMC-DN01



CMC-MOD01  
CMC-EIP01



EMC-COP01



## Analog I/O switch

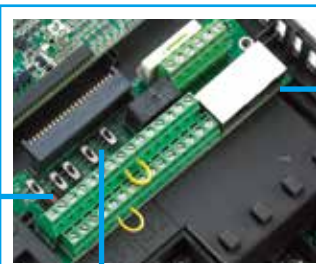
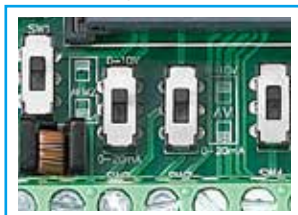

## Termination resistor

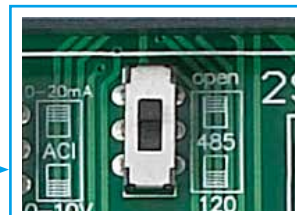

## Dual RJ45 communication ports



**The modular design fulfills the needs of system applications and equipment maintenance.**

- KPC-CC01 keypad
- Standard RJ45 network cable for remote operation.
- Easy to remove with one press.

- The product nameplate shows the input / output voltage, input / output current, the frequency range, and more.
- Remove the safety screws and press on both side tabs to remove the cover.
- Modular fan design, easy to replace and clean, extending product service life.
- RFI Jumper

**Excellent Environment Adaptability**

- ▶ Built-in DC choke to suppress harmonics\*
- ▶ Built-in EMC filter to filter noise\*
- ▶ Conformal coating (Class 3C2 of IEC60721-3-3 standard) ensures drive operation stability and safety in critical environments.
- ▶ The electronic components of the drive are isolated from the cooling system to reduce heat interference. Dissipated heat can be discharged by flange-mounting installation, and forced fan cooling can import cold air into the heat sink. The heat dissipation performance is optimized by these two cooling methods.

\*Note: Please refer to the Product Specification



**Certifications**

<b>UL, cUL</b>	<b>CE</b>
<b>C-Tick</b>	Low Voltage: EN61800-5-1
<b>ROHS</b>	EMC: EN61000-3-12, EN61800-3, IEC61000-6-2, IEC61000-6-4, IEC61000-4-2, IEC61000-4-3, IEC61000-4-4, IEC61000-4-5, IEC61000-4-6, IEC61000-4-8,

# Quick and Easy Parameters Setting via the LCD Keypad

- Multi-column display for the drive status
- Simple and intuitive operation
- User-defined parameter groups
- Real Time Clock and calendar function
- Language selection for display
- Copy function saves parameters and PLC programs to the keypad memory for later transfer to another drive
- IP66 protection level

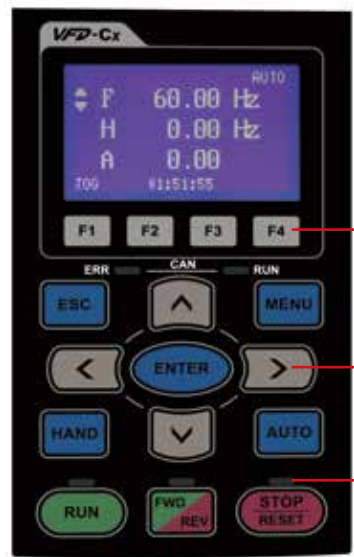

F1 to F4: User-defined function keys

Selection keys

LED displays the current drive status



Create homepage logo

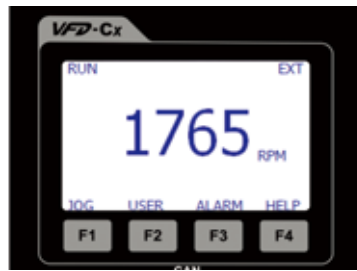

Editable message display

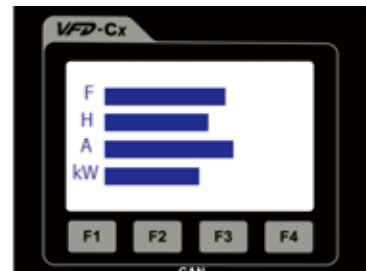

Editable chart display

# Intelligent PLC Functions

- Built-in 10K steps capacity of PLC functions. Distributed control and independent operation are easily achieved via network connection.
- CANopen Master protocol and PLC functions provide synchronous control and fast data exchange.

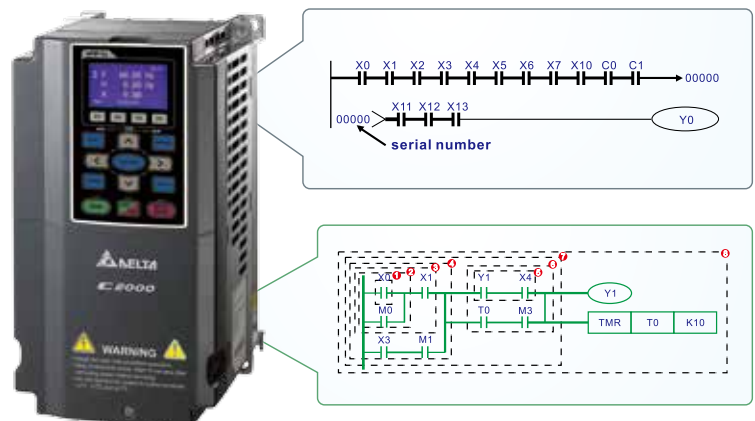



# High-Speed Network

- ▶ Provides optional MODBUS RTU and various fieldbus cards for flexible applications



## ■ CANopen (DS402)

**Ability to control up to 8 Slave drives via the CANopen Master function**

- Supports all Delta industrial automation products (Built-in EDS files for all Delta industrial automation products)
- I/O data configurations for each device on the CANopen network
- Motion control planning function
- WPL Soft

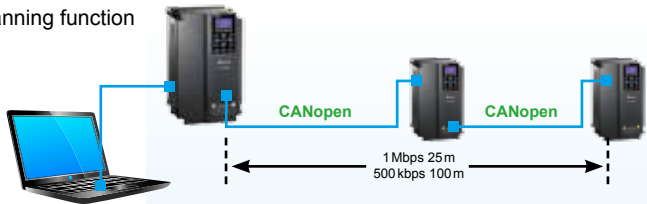

- TAP-CN03 distribution box for long distances



- RJ45 cable

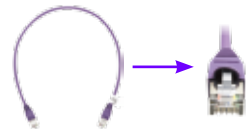

## ■ DeviceNet

**Through the Delta specially designed DeviceNet Builder software, users can easily establish a standard DeviceNet control network by the parameter pre-assignment function for each equipment and remote I/O.**

- Supports all Delta industrial automation products (Built-in EDS files for all Delta industrial automation products)
- I/O data configurations for each device on the DeviceNet network
- DeviceNet layout software



## ■ EtherNet/IP

### ■ MODBUS TCP

**Delta provides communication integrator software that offers graphic module settings and a user friendly interface to support all Ethernet products settings and online monitoring.**

- Delta software for Ethernet/MODBUS TCP products
- Graphic module settings and a user friendly interface
- Auto search function
- Supports Virtual COM settings



# Convenient Drive System Management Platform

- Provides a complete operation platform for users' easy control and monitoring via PC, including parameters save/setting, real-time wave monitor, quick setup, for multiple languages and with multi-language operation systems.

**Start-up display**  
Displays horsepower, rated voltage and current of the drive in use.

**Parameter management**  
Provides parameter setting/save/copy/comparison for convenient parameter management.

**Trend records**  
Monitors the drive operation form via network and displays I/O terminal status. Useful for tasks such as "trial run monitoring".

**Quick setup**  
Guides the user step-by-step through the drive settings according to quick setup wizard.

\*NOTE: These software programs are available for download on Delta's website

# High-Performance Field Oriented Control

The FOC+PG mode of C2000 Series can output 150% of starting torque at extremely low speeds for precise and stable speed control.

Precise position and speed control ideal for printing machine applications.

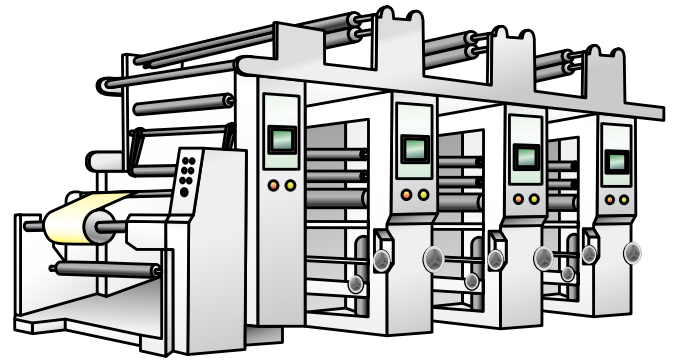
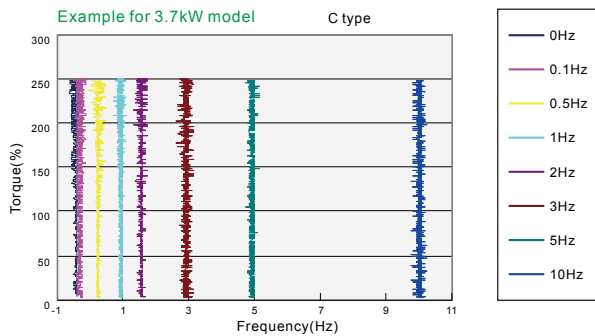

# Fast Response to Impact Load

During load changes, the C2000 Series calculates the required torque response and minimizes the vibration caused by load impact using FOC.

# Auto Energy-Saving Operation

Auto-calculates the optimal voltage for the load output using load power when under constant speed operation.

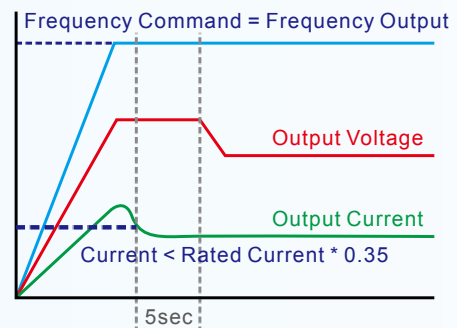
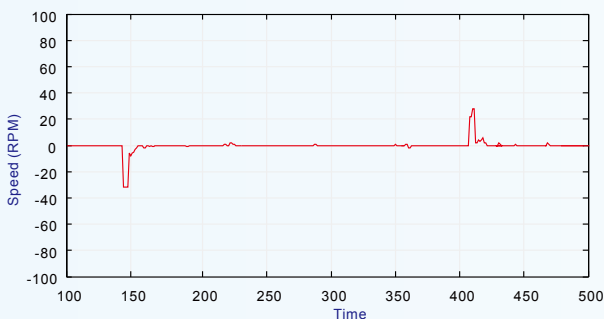

# Deceleration Energy Backup (DEB)

This function controls the motor deceleration to stop when power blinks off to prevent mechanical damage and then accelerates to its original operation speed when power resumes.

— Input Voltage  
— Motor Speed

— Input Voltage  
— Motor Speed

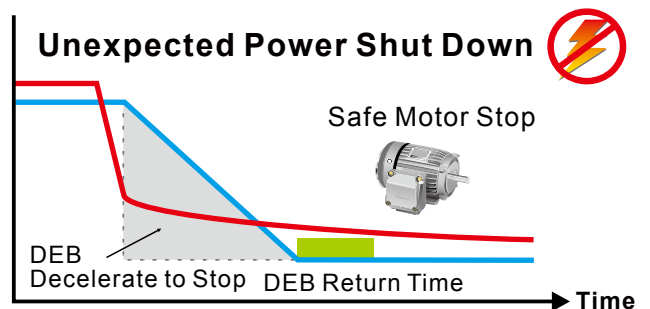
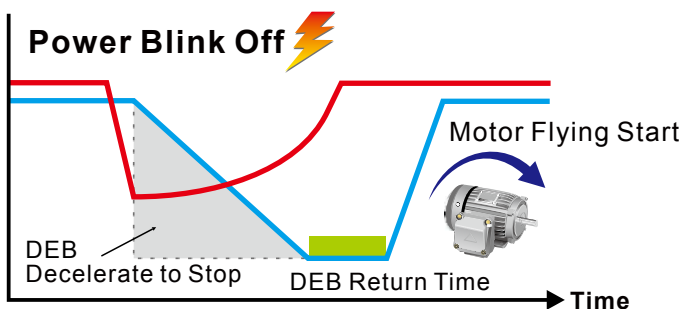

## A Drive for Permanent Magnet (PM) Motors

The C2000 is a dual mode drive to control both an induction motor and permanent magnet motor. The dynamic response of a PM motor provides precise control of position, speed and torque.

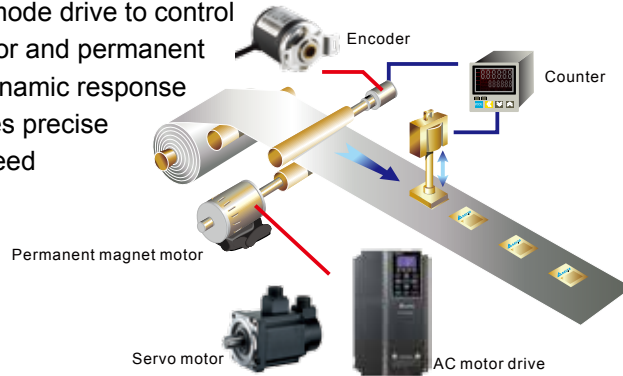

## Delta REG2000 Series for Power Regeneration

Using the REG2000 with the C2000 in a crane and hoist application provides the user with a four-quadrant operation and energy saving results.



## Delta AFE2000 Series for Power Regeneration and Power Quality Improvement

The Active Front End Unit (AFE2000) helps to reduce torque ripple and harmonics with a higher power factor to provide excellent production quality and outstanding energy saving results.



# Delta Active Front End AFE2000 Series

## Features

- Replaces traditional brake resistor to reduce heat generation.
- Clear energy savings: more than 95% of the regenerative energy is converted into electricity and supplied back to the mains.
- Full-load operation: input-side current THD lower than 5% and improves power factor up to 99%.
- AC motor drives with AFE2000: supports 4-quadrant operation with variable frequencies and adjustable system.
- Constant DC bus voltage: unaffected by mains voltage fluctuations.



**Improves power factor and decreases harmonic distortion.**  
THD ≤ 5%, power factor > 99%

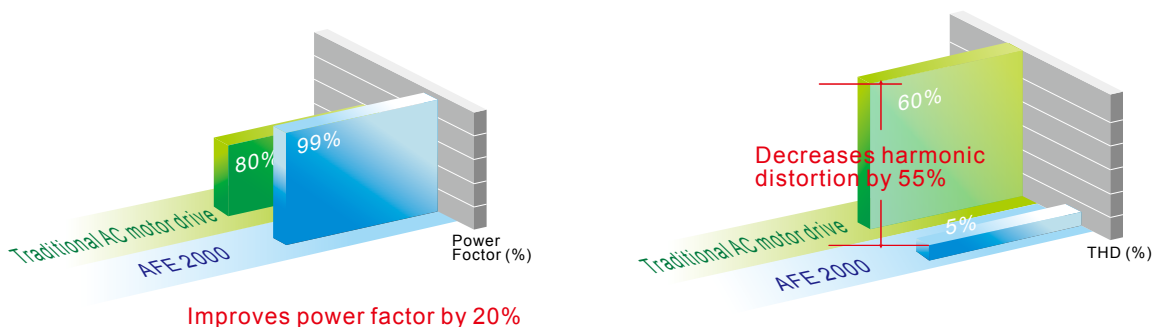

## Applications

- Large-inertia loads, such as centrifuge equipment, dewatering machines and roving machines
- 4-quadrant loads including elevators, cranes and pumpjacks (oil extraction machines)
- Quick braking, such as machine tools, bag making machines, auto storage and retrieval systems, and lathes
- Long-term energy feedback, such as wind power, water power, steel printing and paper making machinery (winding equipment)
- Improves power quality for industries such as semiconductor and panel industries

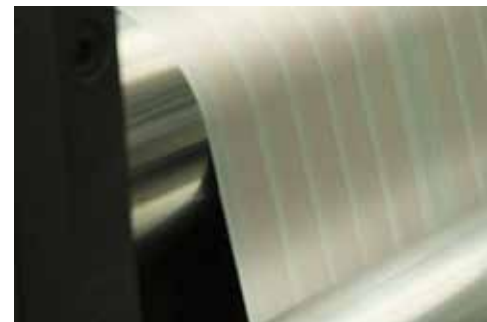

# Operation Temperature and Protection Level

Model	Frame	Top Cover	Conduit Box	Protection Level	Operation Temperature
VFDxxxCxxA VFDxxxCxxS	Frame A ~ C 230V: 0.75 ~ 22kW 460V: 0.75 ~ 30kW	Remove top cover	Standard conduit plate	IP20 / UL Open Type	-10°C ~ 50°C
		Standard with top cover		IP20 / UL Type1 / NEMA1	-10°C ~ 40°C
	Frame D ~ H 230V: > 22kW 460V: > 30kW	N / A	No conduit box	 Protection degree for the circled area is IP00, other areas are IP20	-10°C ~ 50°C
VFDxxxCxxE VFDxxxCxxU	Frame A ~ C 460V: 0.75 ~ 30kW	Remove top cover	Standard conduit plate	IP20 / UL Open Type	-10°C ~ 50°C
		Standard with top cover		IP20 / UL Type1 / NEMA1	-10°C ~ 40°C
	Frame D ~ H 230V: > 22kW 460V: > 30kW	N / A	Standard conduit box	IP20 / UL Type1 / NEMA1	-10°C ~ 40°C
VFDxxxC53A-21 VFDxxxC63B-21	Frame A ~ C 1.5 ~ 37kW	Remove top cover	Standard conduit plate	IP20 / UL Open Type	-10°C ~ 50°C
		Standard with top cover		IP20 / UL Type1 / NEMA1	-10°C ~ 40°C
VFDxxxC63B-21	Frame D ~ H > 45kW	N / A	Standard conduit box	IP20 / UL Type1 / NEMA1	-10°C ~ 40°C
VFDxxxC63B-00	Frame D ~ H > 45kW	N / A	No conduit box	 Protection degree for the circled area is IP00, other areas are IP20	-10°C ~ 50°C

\*Note: HD= Heavy duty; ND= Normal duty; LD =Light duty



# Environment for Operation, Storage and Transportation

DO NOT expose the AC motor drive to harsh environments, such as dust, direct sunlight, corrosive/flammable gasses, humidity, liquid or vibrations. The salts in the air must be less than 0.01 mg/cm<sup>2</sup> per year.

Environment	<b>Installation Location</b>	IEC60364-1/IEC60664-1 Pollution degree 2, indoor use only	
	<b>Surrounding Temperature</b>	Storage/Transportation	-25°C ~ +70°C
		Only allowed in non-condensation, non-frost, non-conductive environment.	
	<b>Rated Humidity</b>	Operation	Max. 95%
		Storage/Transportation	Max. 95%
		Only allowed in non-condensation, non-frost, non-conductive environment.	
	<b>Air Pressure</b>	Operation/Storage	86 to 106kPa
		Transportation	70 to 106kPa
	<b>Pollution Level</b>	IEC60721-3-3	
		Operation	Class 3C2; Class 3S2
Storage		Class 1C2; Class 1S2	
Transportation		Class 2C2; Class 2S2	
Only allowed in non-condensation, non-frost, non-conductive environment.			
<b>Altitude</b>	Operation	If the AC motor drive is installed at an altitude 0 ~ 1000m, follow normal operation restriction. If it is installed at altitude 1000 ~ 3000m, decrease 1% of rated current or lower 0.5°C of temperature for every 100m increase in altitude. Maximum altitude for Corner Grounded TN system is 2000m, for application over 2000m please contact Delta for more details.	
<b>Package Drop</b>	Storage/Transportation	ISTA procedure 1A (according to weight) IEC60068-2-31	
<b>Vibration</b>	1.0mm, peak to peak value range from 2Hz to 13.2Hz; 0.7G ~ 1.0G range from 13.2 Hz to 55Hz; 1.0G range from 55Hz to 512Hz. Comply with IEC 60068-2-6.		
<b>Impact</b>	IEC/EN 60068-2-27		
<b>Operation Position</b>	Max. allowed offset angle ±10° (under normal installation position)		

## Specifications

230V																			
Frame Size		A			B			C			D		E		F				
Model VFD- □□□C□□		007	015	022	037	055	075	110	150	185	220	300	370	450	550	750	900		
Applicable Motor Output (kW)		0.75	1.5	2.2	3.7	5.5	7.5	11	15	18.5	22	30	37	45	55	75	90		
Applicable Motor Output (HP)		1	2	3	5	7.5	10	15	20	25	30	40	50	60	75	100	125		
Output Rating	NORMAL DUTY	Rated Output Capacity (kVA)		2.0	3.2	4.4	6.8	10	13	20	26	30	36	48	58	72	86	102	138
		Rated Output Current (A)		5	8	11	17	25	33	49	65	75	90	120	146	180	215	255	346
	OVERLOAD CAPACITY		120% of rated current: 1 minute for every 5 minutes; 160% of rated current: 3 seconds for every 30 seconds																
	Max. Output Frequency (Hz)		0.00 ~ 599.00Hz																
Carrier Frequency (kHz)		2 ~ 15kHz (default setting 8kHz)					2 ~ 10kHz (default setting 6kHz)					2 ~ 9kHz (default setting 4kHz)							
HEAVY DUTY	Rated Output Capacity (kVA)		1.9	2.8	4.0	6.4	9.6	12	19	25	28	34	45	55	68	81	96	131	
	Rated Output Current (A)		4.8	7.1	10	16	24	31	47	62	71	86	114	139	171	204	242	329	
	OVERLOAD CAPACITY		150% of rated current: 1 minute for every 5 minutes; 180% of rated current: 3 seconds for every 30 seconds																
	Max. Output Frequency (Hz)		0.00 ~ 300.00Hz																
Carrier Frequency (kHz)		2 ~ 6kHz (default setting 2kHz)																	
Input Rating	Input Current (A) Normal Duty		6.4	12	16	20	28	36	52	72	83	99	124	143	171	206	245	331	
	Input Current (A) Heavy Duty		6.1	11	15	18.5	26	34	50	68	78	95	118	136	162	196	233	315	
	Rated Voltage/Frequency		3-phase AC 200V ~ 240V (-15% ~ +10%), 50/60Hz																
	Operating Voltage Range		170 ~ 265V <sub>ac</sub>																
Frequency Tolerance		47 ~ 63Hz																	
Drive Weight		2.6 ± 0.3Kg			5.4 ± 1Kg			9.8 ± 1.5Kg			38.5 ± 1.5Kg		64.8 ± 1.5Kg		86.5 ± 1.5Kg				
Efficiency (%)		97.8																	
Power Factor		> 0.98																	
Cooling Method		Natural cooling					Fan cooling												
Braking Chopper		Frame A, B, C: built-in										Frame D and above: optional							
DC Choke		Frame A, B, C: optional										Frame D and above: built-in							
EMC Filter		Optional external EMC filter is available upon purchase																	
EMC-COP01		Optional																	

\* The factory setting is Normal Duty mode

## 460V

Frame Size		A					B			C								
Model VFD-□□□C□□		007	015	022	037	040	055	075	110	150	185	220	300					
Applicable Motor Output (kW)		0.75	1.5	2.2	3.7	4.0	5.5	7.5	11	15	18.5	22	30					
Applicable Motor Output (HP)		1	2	3	5	5	7.5	10	15	20	25	30	40					
Output Rating	NORMAL DUTY*	Rated Output Capacity (kVA)		2.4	3.2	4.8	7.2	8.4	10	14	19	25	30	36	48			
		Rated Output Current (A)		3.0	4.0	6.0	9.0	10.5	12	18	24	32	38	45	60			
		Overload Capacity																
		120% of rated current: 1 minute for every 5 minutes; 160% of rated current: 3 seconds for every 30 seconds																
		Max. Output Frequency (Hz)																
		0.00 ~ 599.00Hz																
Output Rating	HEAVY DUTY	Rated Output Capacity (kVA)					2.3	3.0	4.5	6.5	7.6	9.6	14	18	24	29	34	45
		Rated Output Current (A)					2.9	3.8	5.7	8.1	9.5	11	17	23	30	36	43	57
		Overload Capacity																
		150% of rated current: 1 minute for every 5 minutes; 180% of rated current: 3 seconds for every 30 seconds																
		Max. Output Frequency (Hz)																
		0.00 ~ 300.00Hz																
Input Rating	Input Current (A) Normal Duty		4.3	5.9	8.7	14	15.5	17	20	26	35	40	47	63				
	Input Current (A) Heavy Duty		4.1	5.6	8.3	13	14.5	16	19	25	33	38	45	60				
	Rated Voltage/Frequency																	
	3-phase AC 380 V ~ 480 V ( -15% ~ +10%), 50/60Hz																	
Operating Voltage Range																		
323 ~ 528 V <sub>AC</sub>																		
Frequency Tolerance																		
47 ~ 63Hz																		
Drive Weight				2.6 ± 0.3Kg				5.4 ± 1 Kg				9.8 ± 1.5Kg						
Efficiency (%)																		
97.8																		
Power Factor																		
> 0.98																		
Cooling Method		Natural cooling	Fan cooling															
Braking Chopper		Frame A, B, C: built-in; Frame D and above: optional																
DC Choke		Frame A, B, C: optional; Frame D and above: built-in																
EMC Filter		Frame A, B, C VFDXXXC43E: built-in EMC filter Frame A, B, C VFDXXXC43A: no EMC filter (Optional external EMC filter is available upon purchase), VFDXXXC43E: built-in																
EMC-COP01		VFDXXXC43A: optional; VFDXXXC43E: built-in																

## 460V

Frame Size		D0		D		E		F		G		H											
Model VFD-□□□C□□		370	450	550	750	900	1100	1320	1600	1850	2200	2800	3150	3550	4500								
Applicable Motor Output (kW)		37	45	55	75	90	110	132	160	185	220	280	315	355	450								
Applicable Motor Output (HP)		50	60	75	100	125	150	175	215	250	300	375	425	475	600								
Output Rating	NORMAL DUTY*	Rated Output Capacity (kVA)		58	73	88	120	143	175	207	247	295	367	438	491	544	720						
		Rated Output Current (A)		73	91	110	150	180	220	260	310	370	460	550	616	683	866						
		Overload Capacity																					
		120% of rated current: 1 minute for every 5 minutes; 160% of rated current: 3 seconds for every 30 seconds																					
		Max. Output Frequency (Hz)																					
		0.00 ~ 599.00Hz																					
Output Rating	HEAVY DUTY	Carrier Frequency (kHz)				2 ~ 10kHz (default setting 6kHz)		2 ~ 9kHz (default setting 4kHz)															
		Rated Output Capacity (kVA)		55	69	84	114	136	167	197	235	280	348	417	466	517	677						
		Rated Output Current (A)		69	86	105	143	171	209	247	295	352	437	523	585	649	815						
		Overload Capacity																					
		150% of rated current: 1 minute for every 5 minutes; 180% of rated current: 3 seconds for every 30 seconds																					
		Max. Output Frequency (Hz)																					
	0.00 ~ 300.00Hz																						
Input Rating	Carrier Frequency (kHz)		2 ~ 6kHz (default setting 2kHz)																				
	Input Current (A) Normal Duty		74	101	114	157	167	207	240	300	380	400	494	555	625	866							
	Input Current (A) Heavy Duty		70	96	108	149	159	197	228	285	361	380	469	527	594	815							
	Rated Voltage/Frequency																						
3 - phase AC 380V ~ 480V ( -15% ~ +10% ), 50/60Hz																							
Operating Voltage Range																							
323 ~ 528 V <sub>AC</sub>																							
Frequency Tolerance																							
47 ~ 63Hz																							
Drive Weight				38.5 ± 1.5Kg				64.8 ± 1.5Kg				86.5 ± 1.5Kg				134 ± 4 Kg				228 Kg			
Efficiency (%)																							
97.8																							
Power Factor																							
> 0.98																							
Cooling Method																							
Fan cooling																							
Braking Chopper																							
Frame A, B, C: built-in; Frame D and above: optional																							
DC Choke																							
Frame A, B, C: optional; Frame D and above: built-in																							
EMC Filter																							
Optional external EMC filter is available upon purchase																							
EMC-COP01																							
VFDXXXC43A: optional; VFDXXXC43E: built-in																							

\* The factory setting is Normal Duty mode

**NOTES:**

- 1) The carrier frequency is default. Increasing the carrier frequency requires a reduction in current. please refer to Pr. 06-55 Derating Protection drawing.
- 2) The AC motor drive should operate in derating current when its control method is set to FOC Sensorless, TQC+PG, TQC sensorless. PM+PG, PM sensorless.
- 3) Select the AC motor drive with capacity one grade larger for the impact load application.
- 4) For Frame A, B and C, Model VFDXXXC43A is under IP20/NEMA1/UL TYPE1 protection level.
- 5) For Frame D and above, if the last character of the model is A then it is under IP20 protection level but the wiring terminal is under IP00 protection level;
- 6) if the last character of the model is E, it is under IP20/NEMA1/UL TYPE1 protection level.

# Specifications

575V									
Frame Size	A			B					
Model VFD-□□□ C53A-21	015	022	037	055	075	110	150		
Applicable Motor Output (HP)	2	3	5	7.5	10	15	20		
Output*	Light Duty	Rated Output Capacity (kVA)	3	4.3	6.7	9.9	12.1	18.7	24.2
		Rated Output Current (A)	3	4.3	6.7	9.9	12.1	18.7	24.2
	Light Duty	Applicable Motor Output (kW)	1.5	2.2	3.7	5.5	7.5	11	15
		Applicable Motor Output (HP)	2	3	5	7.5	10	15	20
	Normal Duty	Rated Output Capacity (kVA)	2.5	3.6	5.5	8.2	10	15.4	19.9
		Rated Output Current (A)	2.5	3.6	5.5	8.2	10	15.5	20
	Normal Duty	Applicable Motor Output (kW)	0.75	1.5	2.2	3.7	5.5	7.5	11
		Applicable Motor Output (HP)	1	2	3	5	7.5	10	15
	Heavy Duty	Rated Output Capacity (kVA)	2.1	3	4.6	6.9	8.3	12.9	16.7
		Rated Output Current (A)	2.1	3	4.6	6.9	8.3	13	16.8
	Heavy Duty	Applicable Motor Output (kW)	0.75	1.5	2.2	3.7	3.7	7.5	7.5
		Applicable Motor Output (HP)	1	2	3	5	5	10	10
	Efficiency (%)	97			98				
	Power Factor	>0.98							
Carrier Frequency (kHz)	2~15kHz (default setting 4 kHz)								
Input	Input Current (A) Light Duty	3.8	5.4	10.4	14.9	16.9	21.3	26.3	
	Input Current (A) Normal Duty	3.1	4.5	7.2	12.3	15	18	22.8	
	Input Current (A) Heavy Duty	2.6	3.8	5.8	10.7	12.5	16.9	19.7	
	Rated Voltage/Frequency	3-Phase 525 V <sub>AC</sub> ~600 V <sub>AC</sub> (-15%~+10%), 50/60 Hz							
	Operating Voltage Range	446~660 V <sub>AC</sub>							
Frequency Tolerance	47~63 Hz								
AC Drive Weight	3±0.3Kg			4.8±1 Kg					
Cooling Method	Natural cooling			Fan cooling					
Braking Chopper				Built-in					
DC Choke				Optional					

690V												
Frame Size	C				D		E					
Model VFD-□□□ C63B-00 / -21	185	220	300	370	450	550	750	900	1100	1320		
Output*	Light Duty	Rated Output Capacity (kVA)	29	36	43	54	65	80	103	124	149	179
		Applicable Motor Output (690V, kW)	18.5	22	30	37	45	55	75	90	110	132
		Applicable Motor Output (690V, HP)	25	30	40	50	60	75	100	125	150	175
		Applicable Motor Output (575V, HP)	20	25	30	40	50	60	75	100	125	150
	Normal Duty	Rated Output Current (A)	24	30	36	45	54	67	86	104	125	150
		Rated Output Capacity (kVA)	24	29	36	43	54	65	80	103	124	149
		Applicable Motor Output (690V, kW)	15	18.5	22	30	37	45	55	75	90	110
		Applicable Motor Output (690V, HP)	20	25	30	40	50	60	75	100	125	150
	Heavy Duty	Applicable Motor Output (575V, HP)	15	20	25	30	40	50	60	75	100	125
		Rated Output Current (A)	20	24	30	36	45	54	67	86	104	125
		Rated Output Capacity (kVA)	17	24	29	36	43	54	65	80	103	124
		Applicable Motor Output (690V, kW)	11	15	18.5	22	30	37	45	55	75	90
	Heavy Duty	Applicable Motor Output (690V, HP)	15	20	25	30	40	50	60	75	100	125
		Applicable Motor Output (575V, HP)	10	15	20	25	30	40	50	60	75	100
Rated Output Current (A)	14	20	24	30	36	45	54	67	86	104		
Efficiency (%)	97											
Power Factor	>0.98											
Carrier Frequency (kHz)	2~9 kHz (default setting 4 kHz)											
Input	Input Current (A) Light Duty	29	36	43	54	65	81	84	102	122	147	
	Input Current (A) Normal Duty	24	29	36	43	54	65	66	84	102	122	
	Input Current (A) Heavy Duty	20	24	29	36	43	54	53	66	84	102	
	Rated Voltage/Frequency	3-Phase 525 V <sub>AC</sub> ~690 V <sub>AC</sub> (-15%~+10%), 50/60 Hz										
	Operating Voltage Range	446~759 V <sub>AC</sub>										
Frequency Tolerance	47~63 Hz											
AC Drive Weight	10±1.5Kg				39±1.5Kg			61±1.5Kg				
Cooling Method					Fan cooling							
Braking Chopper	Frame C (built-in)				Frame D and above (optional)							
DC Choke	Frame C (optional)				Frame D and above (built-in)							

\* Parameter 00-16; available load modes: Light Duty (LD), Normal Duty (ND) and Heavy Duty (HD); default setting is LD mode



## 690V

Frame Size		F		G		H				
Model VFD-□□□C63B-00 / -21		1600	2000	2500	3150	4000	4500	5600	6300	
Output*	Light Duty									
	Rated Output Capacity (kVA)	215	263	347	418	494.5	534.7	678.5	776	
	Applicable Motor Output (690V, kW)	160	200	250	315	400	450	560	630	
	Applicable Motor Output (690V, HP)	215	270	335	425	530	600	745	850	
	Applicable Motor Output (575V, HP)	150	200	250	350	400	450	500	675	
	Rated Output Current (A)	180	220	290	350	430	465	590	675	
	Normal Duty									
	Rated Output Capacity (kVA)	179	215	239	347	402.5	442.7	534.7	776	
	Applicable Motor Output (690V, kW)	132	160	200	250	315	355	450	630	
	Applicable Motor Output (690V, HP)	175	215	270	335	425	475	600	850	
	Applicable Motor Output (575V, HP)	150	150	200	250	350	400	450	500	
	Rated Output Current (A)	150	180	220	290	350	385	465	675	
	Heavy Duty									
	Rated Output Capacity (kVA)	149	179	215	263	333.5	356.5	483	776	
	Applicable Motor Output (690V, kW)	110	132	160	200	250	280	400	630	
	Applicable Motor Output (690V, HP)	150	175	215	270	335	375	530	850	
Applicable Motor Output (575V, HP)	125	150	150	200	250	350	450	500		
Rated Output Current (A)	125	150	180	220	290	310	420	675		
Efficiency (%)	97		98							
Power Factor	> 0.98									
Carrier Frequency (kHz)	2~9 kHz (default setting 4 kHz)								2~9 kHz (default setting 3 kHz)	
Input	Input Current (A) Light Duty	178	217	292	353	454	469	595	681	
	Input Current (A) Normal Duty	148	178	222	292	353	388	504	681	
	Input Current (A) Heavy Duty	123	148	181	222	292	313	423	681	
	Rated Voltage/Frequency	3-Phase 525 V <sub>AC</sub> ~690 V <sub>AC</sub> (-15%~+10%), 50/60 Hz								
	Operating Voltage Range	446~759 V <sub>AC</sub>								
Frequency Tolerance	47~63 Hz									
AC Drive Weight	88 ± 1.5 Kg		135 ± 4 Kg		243 ± 5 Kg					
Cooling Method	Fan cooling									
Braking Chopper	Frame D and above (optional)									
DC Choke	Frame D and above (built-in)									

\* Parameter 00-16; available load modes: Light Duty (LD), Normal Duty (ND) and Heavy Duty (HD); default setting is LD mode



# General Specifications

Control Characteristics	<b>Control Method</b>	Pulse Width Modulated (PWM)
	<b>Control Mode</b>	230 V / 460 V model: 1: V/F · 2: SVC · 3: VF+PG · 4: FOC+PG · 5: TQC+PG · 6: PM+PG · 7: FOC sensorless · 8: TQC sensorless · 9: PM sensorless
		575 V / 690 V model: 1: V/F · 2: V/F+PG · 3: SVC
	<b>Starting Torque</b>	Reach up to 150% or above at 0.5Hz. Under FOC+PG mode, starting torque can reach 150% at 0Hz
	<b>V/F Curve</b>	4-point adjustable V/F curve and square curve
	<b>Speed Response Ability</b>	5Hz (vector control can reach up to 40Hz)
	<b>Torque Limit</b>	230 V / 460 V model: Normal duty 160%, heavy duty 180% of torque current ; 575 V / 690 V model: Maximum 200% of torque current
	<b>Torque Accuracy at TQC Mode</b>	TQC + PG : ±5% TQC Sensorless : ±15%
	<b>Max. Output Frequency (Hz)</b>	Light Duty / Normal duty: 0.01 ~ 599.00Hz; Heavy duty: 0.00 ~ 300.00Hz
	<b>Frequency Output Accuracy</b>	Digital command: ±0.01%, -10° C ~ +40° C, Analog command: ±0.1%, 25 ±10° C
	<b>Output Frequency Resolution</b>	Digital command: 0.01 Hz, Analog command: 0.03 * max. output frequency/60Hz (±11bit)
	<b>Overload Capacity</b>	230 V / 460 V model: Normal duty: 120%, 1 minute every 5 minutes; 160%, 3 seconds every 30 seconds Heavy duty: 150%, 1 minute every 5 minutes; 180%, 3 seconds every 30 seconds
		575 V / 690 V model: Light duty: rated output current is 120% for 60 seconds Normal duty: rated output current is 120% for 60 seconds; 150% for 3 seconds Heavy duty: rated output current is 150% for 60 seconds; 180% for 3 seconds
	<b>Frequency Setting Signal</b>	+10V ~ -10, 0 ~ +10V, 4 ~ 20 mA, 0 ~ 20 mA, pulse input
<b>Accel./decel. Time</b>	0.00 ~ 600.00 / 0.0 ~ 6000.0 Seconds	
<b>Main Control Function</b>	Torque control, Speed/torque control switching, Feed forward control, Zero-servo control, Momentary power loss ride thru, Speed search, Over-torque detection, Torque Limit, 16-step speed (Max.), Accel./decel time switch, S-curve accel/decel, 3-wire sequence, Auto-Tuning (rotational, stationary), Dwell, Slip compensation, Torque compensation, JOG frequency, Fault restart, Frequency upper/lower limit settings, DC injection braking at start/stop, High slip braking, Parameter copy PID control (with sleep function), Energy saving control, MODOBUS communication (RS-485 RJ45, Max. 115.2 kbps)	
<b>Fan Control</b>	230 V model: VFD150C23A (include) and series above: PMW control; VFD110C23A and below: on/off switch control	
	460 V model: VFD185C43A (include) and series above: PMW control; VFD150C43A and below: on/off switch control 575 V / 690 V model: PWM control	
Protection Characteristics	<b>Motor Protection</b>	Electronic thermal relay protection
	<b>Over-current Protection</b>	230 V / 460 V model: Over-current protection for 240% of rated current Current clamp (Normal duty: around 170 ~ 175%); (Heavy duty: around 180 ~ 185%)
		575 V / 690 V model: Over-current protection for 225% rated current Current clamp (Light duty: around 128 ~ 141%); (Normal duty: around 170 ~ 175%); (Heavy duty: around 202% ~ 210%)
	<b>Over-Voltage Protection</b>	The C2000 Series will shut down under below conditions: 230 V: DC bus over 410V; 460 V: DC bus over 820V; 575 V / 690 V: DC bus over 1189 V
	<b>Over-Temperature Protection</b>	Built-in temperature sensor
	<b>Stall Prevention</b>	Stall prevention during acceleration, deceleration and running independently
	<b>Restart after Instantaneous Power Failure</b>	Parameter setting up to 20 seconds
<b>Grounding Leakage Current Protection</b>	Leakage current is higher than 50% of rated current of the AC motor drive	
<b>International Certifications</b>		

Note: EAC Certification is for 230V and 460V models only

# Wiring

## Wiring Diagram for Frame A~C

\*Input: 3-phase power

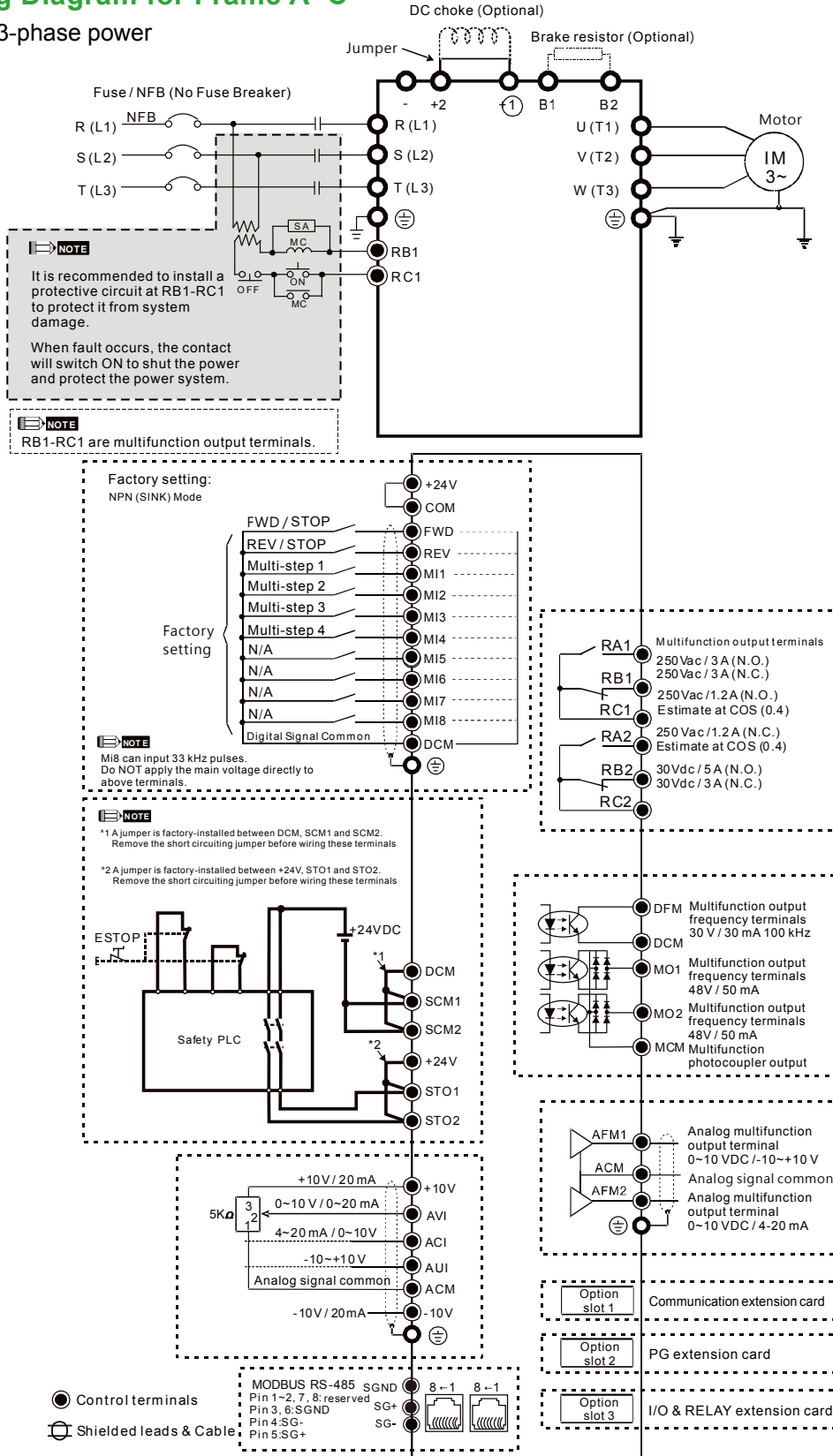

Note: It is not recommended to use a power capacitor or automatic power factor regulator (APFR) at the power input side. If the system requires such a device, please make sure a reactor is installed between the drive and the power capacitor or APFR.

# Wiring

## Wiring Diagram for Frame D and Frames Above

\*Input: 3-phase power

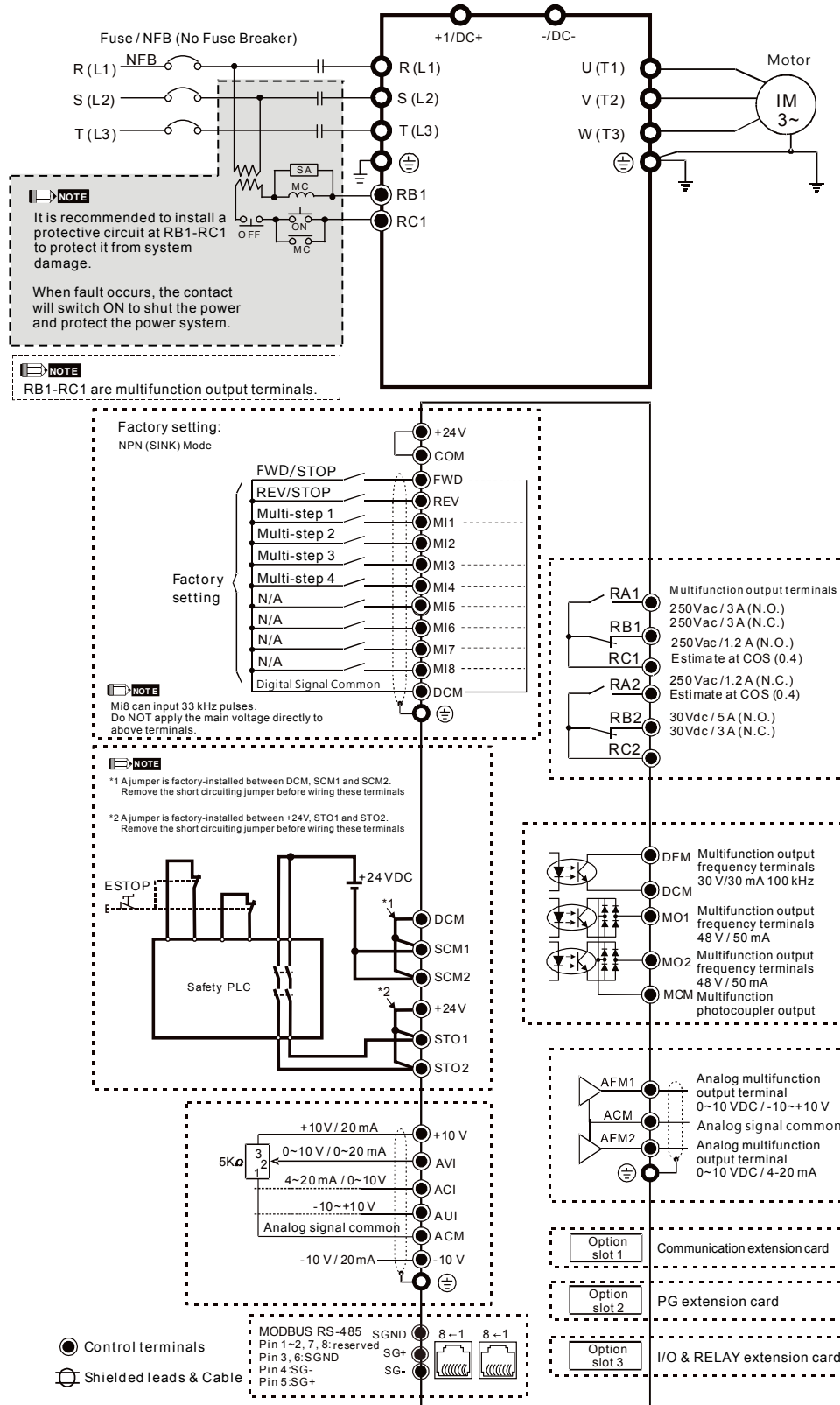

# Dimensions

## Digital Keypad

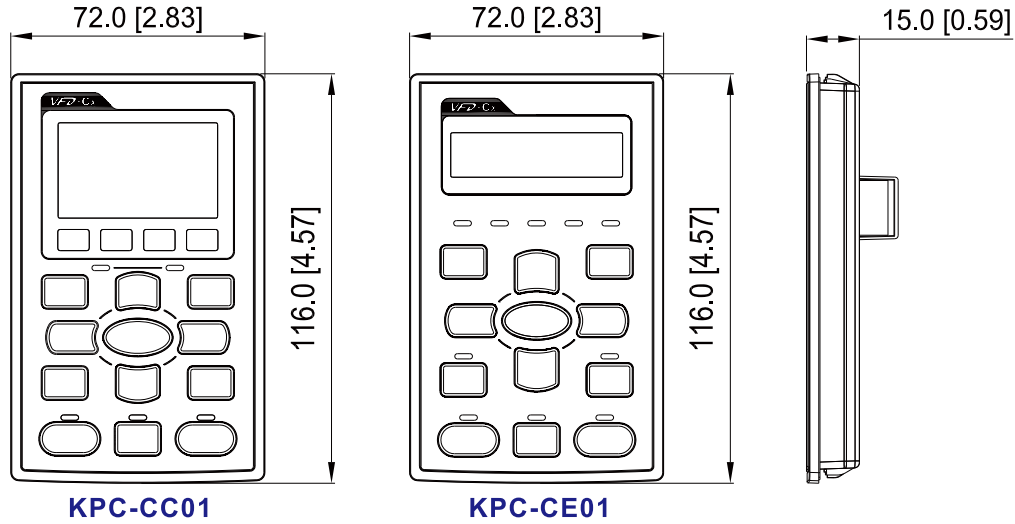

## Frame A

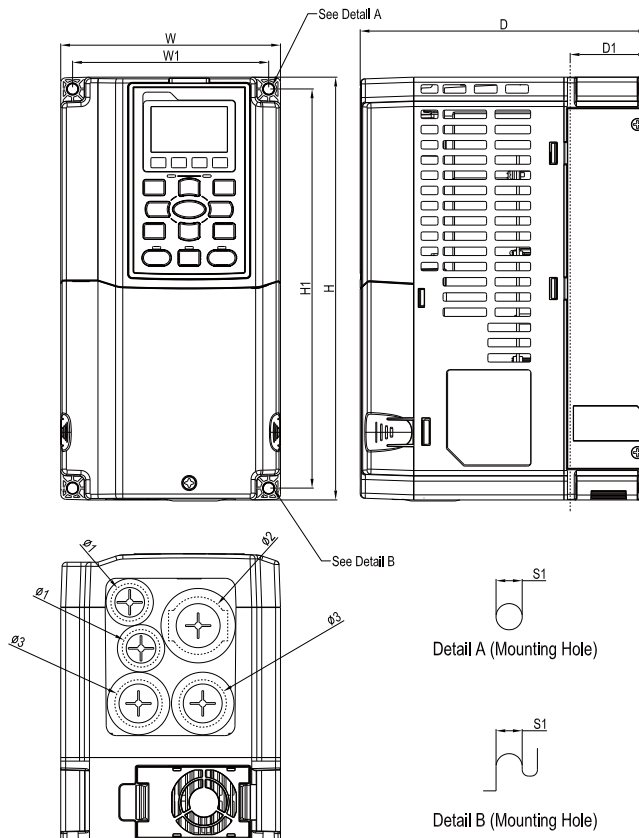

### MODEL FRAME\_A

- VFD007C23A
- VFD015C23A
- VFD022C23A
- VFD037C23A
- VFD007C43A / 43E
- VFD015C43A / 43E
- VFD022C43A / 43E
- VFD037C43A / 43E
- VFD040C43A / 43E
- VFD055C43A / 43E
- VFD015C53A-21
- VFD022C53A-21
- VFD037C53A-21

Frame		W	H	D	W1	H1	D1*	Ø	Ø1	Ø2	Ø3
A1	mm	130.0	250.0	170.0	116.0	236.0	45.8	6.2	22.2	34.0	28.0
	inch	5.12	9.84	6.69	4.57	9.29	1.80	0.24	0.87	1.34	1.10

\*D1: Flange mount.

# Dimensions

## Frame B

### MODEL

VFD055C23A  
 VFD075C23A  
 VFD110C23A  
 VFD075C43A / 43E  
 VFD110C43A / 43E  
 VFD150C43A / 43E  
 VFD055C53A-21  
 VFD075C53A-21  
 VFD110C53A-21  
 VFD150C53A-21

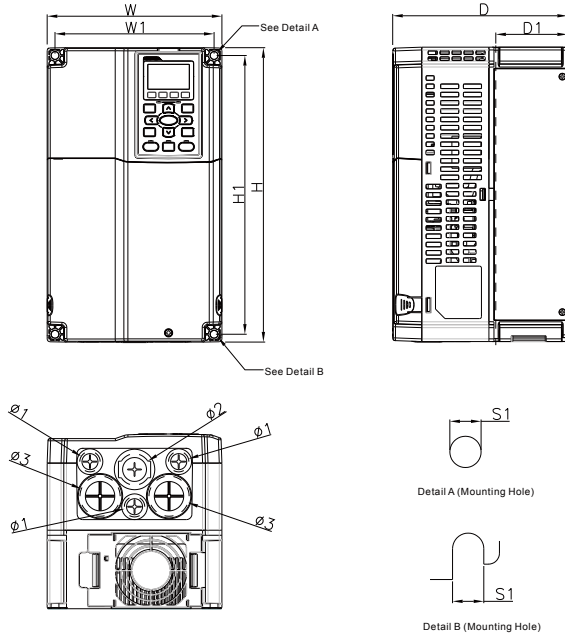

Frame		W	H	D	W1	H1	D1*	S1	$\phi 1$	$\phi 2$	$\phi 3$
B1	mm	190.0	320.0	190.0	173.0	303.0	77.9	8.5	22.2	34.0	28.0
	inch	7.48	12.60	7.48	6.81	11.93	3.07	0.33	0.87	1.34	1.10

\*D1: Flange mount.

## Frame C

### MODEL

VFD150C23A  
 VFD185C23A  
 VFD220C23A  
 VFD185C43A / 43E  
 VFD220C43A / 43E  
 VFD300C43A / 43E  
 VFD185C63B-21  
 VFD220C63B-21  
 VFD300C63B-21  
 VFD370C63B-21

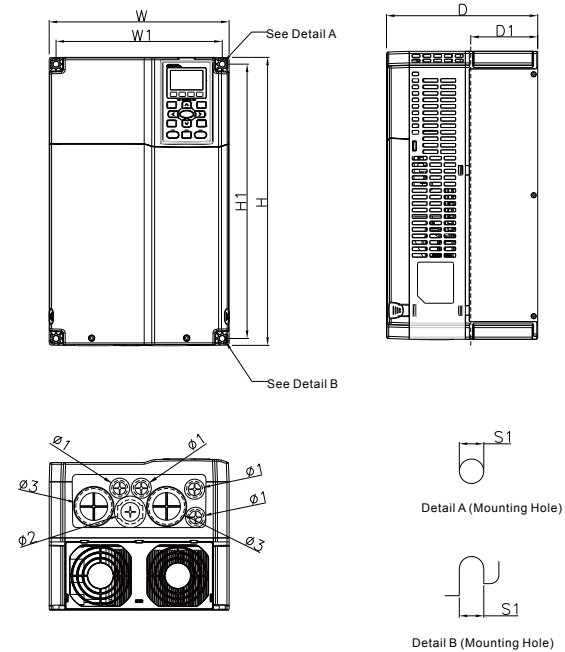

Frame		W	H	D	W1	H1	D1*	S1	$\phi 1$	$\phi 2$	$\phi 3$
C1	mm	250.0	400.0	210.0	231.0	381.0	92.9	8.5	22.2	34.0	50.0
	inch	9.84	15.75	8.27	9.09	15.00	3.66	0.33	0.87	1.34	1.97

\*D1: Flange mount.

## Frame D

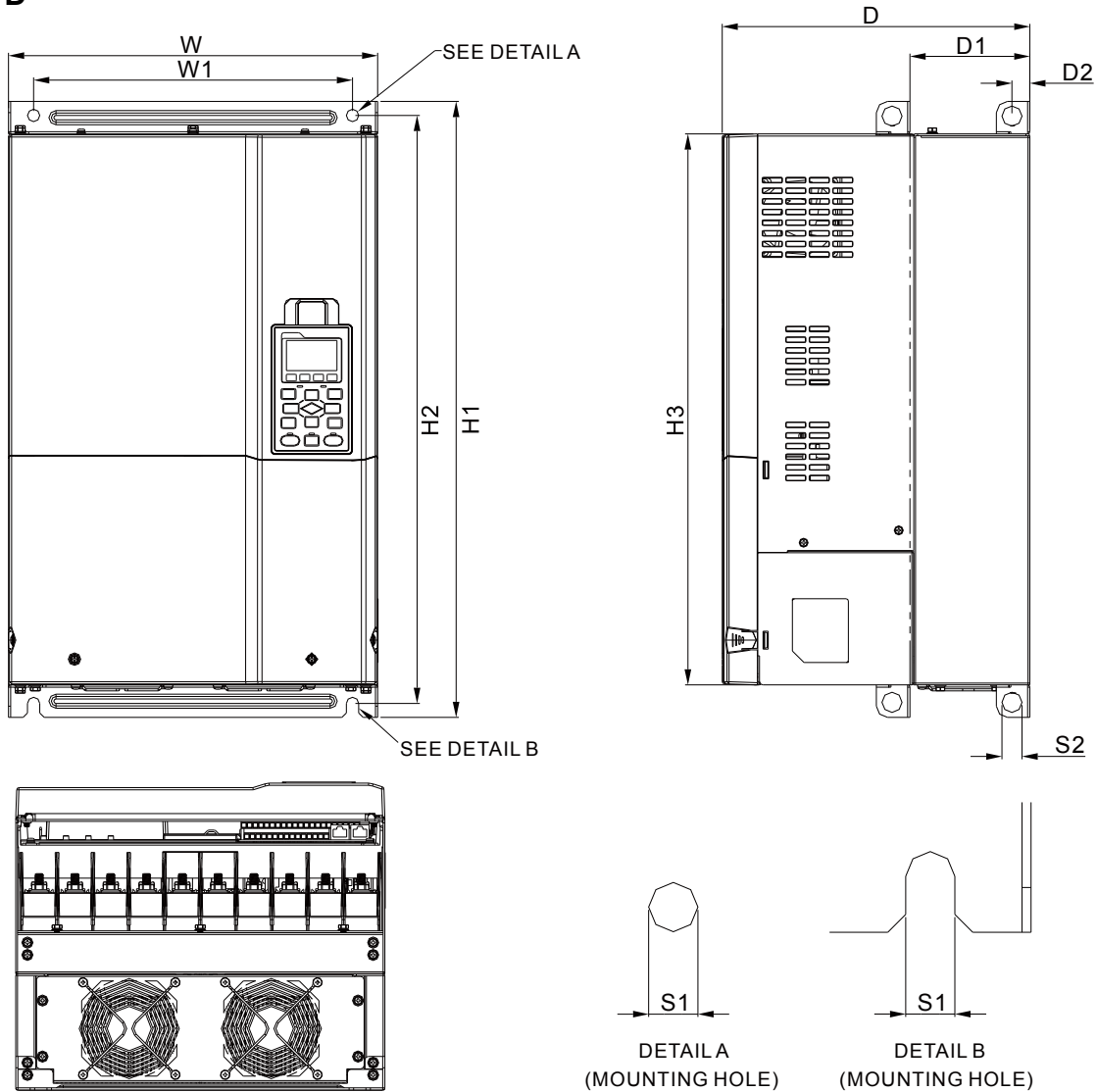

MODEL	FRAME_D1	FRAME_D0-1
VFD300C23A		VFD370C43S
VFD370C23A		VFD450C43S
VFD550C43A		
VFD750C43A		
VFD450C63B-00		
VFD550C63B-00		

Frame	W	H	D	W1	H1	H2	H3	D1*	D2	S1	S2	Ø1	Ø2	Ø3	
D1	mm	330.0	-	275.0	285.0	550.0	525.0	492.0	107.2	16.0	11.0	18.0	-	-	-
	inch	12.99	-	10.83	11.22	21.65	20.67	19.37	4.22	0.63	0.43	0.71	-	-	-
Frame	W	H	D	W1	H1	H2	H3	D1*	D2	S1	S2	Ø1	Ø2	Ø3	
D0-1	mm	280.0	-	255.0	235.0	500.0	475.0	442.0	94.2	16.0	11.0	18.0			
	inch	11.02	-	10.04	9.25	19.69	18.70	17.40	3.71	0.63	0.43	0.71			

\*D1: Flange mount.

# Dimensions

## Frame D

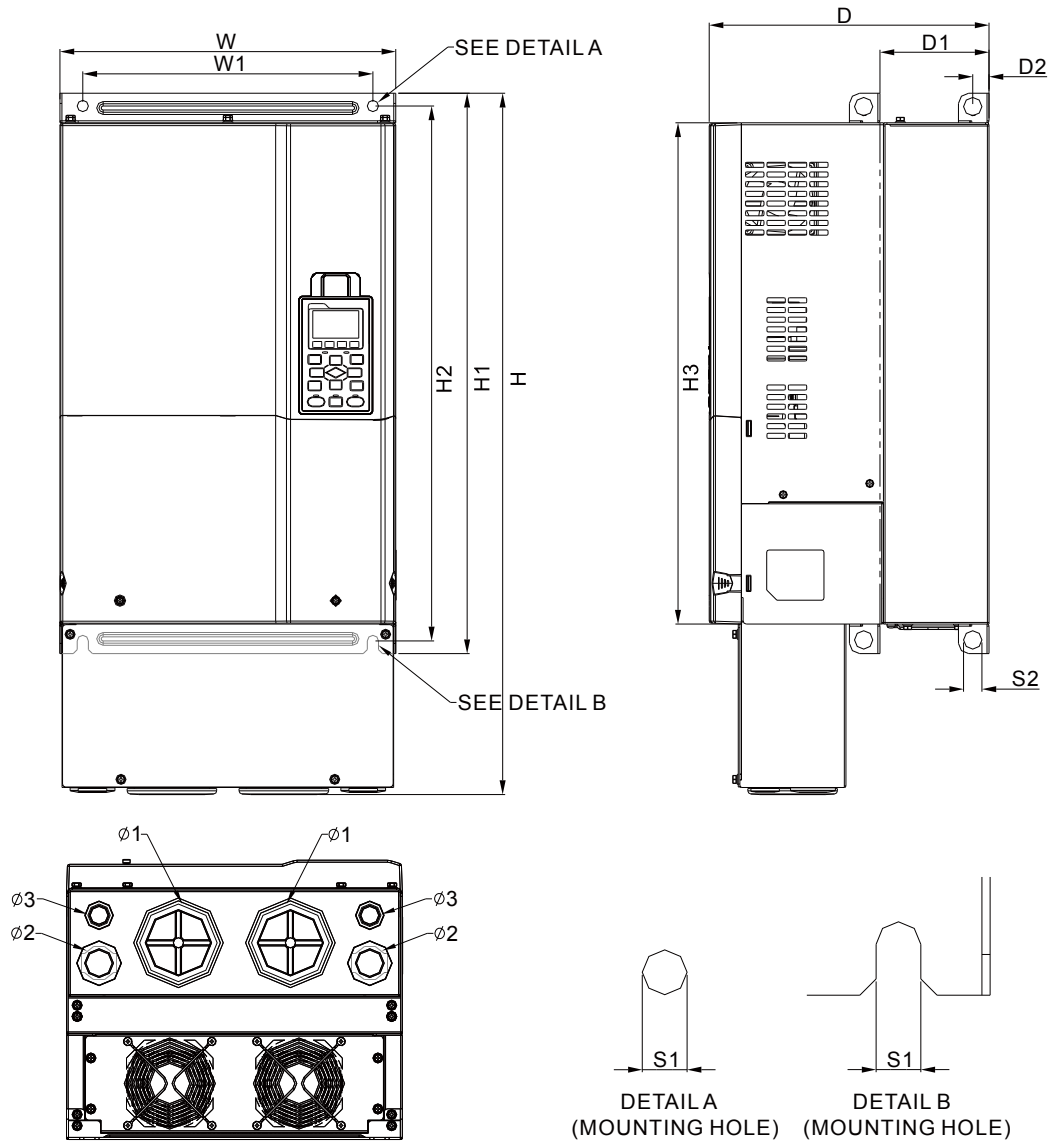

MODEL	FRAME_D2	FRAME_D0-2
VFD300C23E		VFD370C43U
VFD370C23E		VFD450C43U
VFD550C43E		
VFD750C43E		
VFD450C63B-21		
VFD550C63B-21		

Frame	W	H	D	W1	H1	H2	H3	D1*	D2	S1	S2	Ø1	Ø2	Ø3
D2	mm	330.0	688.3	275.0	285.0	550.0	525.0	107.2	16.0	11.0	18.0	76.2	34.0	22.0
	inch	12.99	27.10	10.83	11.22	21.65	20.67	4.22	0.63	0.43	0.71	3.00	1.34	0.87
Frame	W	H	D	W1	H1	H2	H3	D1*	D2	S1	S2	Ø1	Ø2	Ø3
D0-2	mm	280.0	614.4	255.0	235.0	475.0	442.0	94.2	16.0	11.0	18.0	62.7	34.0	22.0
	inch	11.02	21.19	10.04	9.25	19.69	18.70	3.71	0.63	0.43	0.71	2.47	1.34	0.87

\*D1: Flange mount.



# Frame E

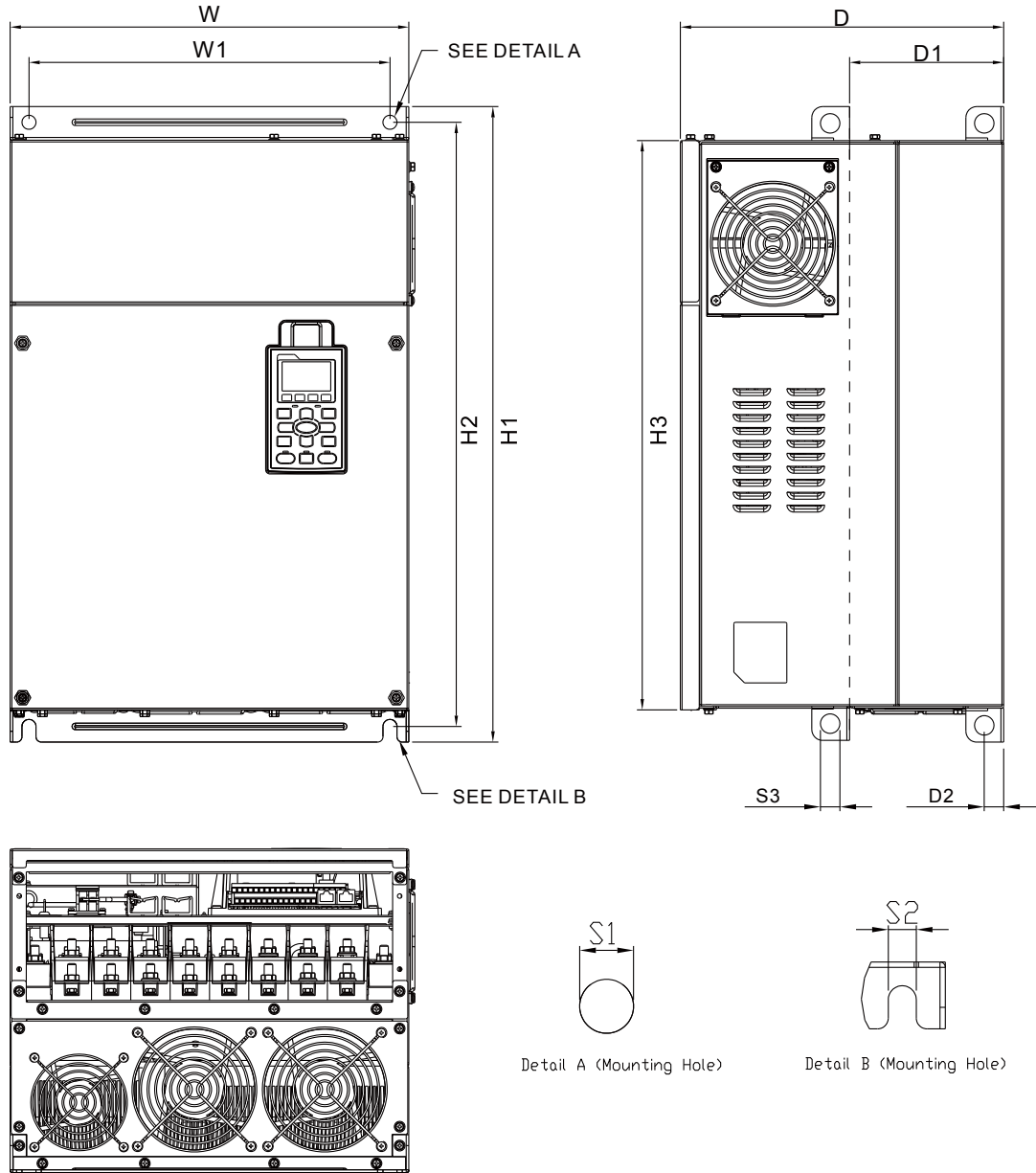

## MODEL FRAME\_E1

VFD450C23A	VFD750C63B-00
VFD550C23A	VFD900C63B-00
VFD750C23A	VFD1100C63B-00
VFD900C43A	VFD1320C63B-00
VFD1100C43A	

Frame	W	H	D	W1	H1	H2	H3	D1*	D2	S1	S2	S3	Ø1	Ø2	Ø3	
E1	mm	370.0	-	300.0	335.0	589	560.0	528.0	143.0	18.0	13.0	13.0	18.0	-	-	-
	inch	14.57	-	11.81	13.19	23.19	22.05	20.80	5.63	0.71	0.51	0.51	0.71	-	-	-

\*D1: Flange mount.

# Dimensions

## Frame E

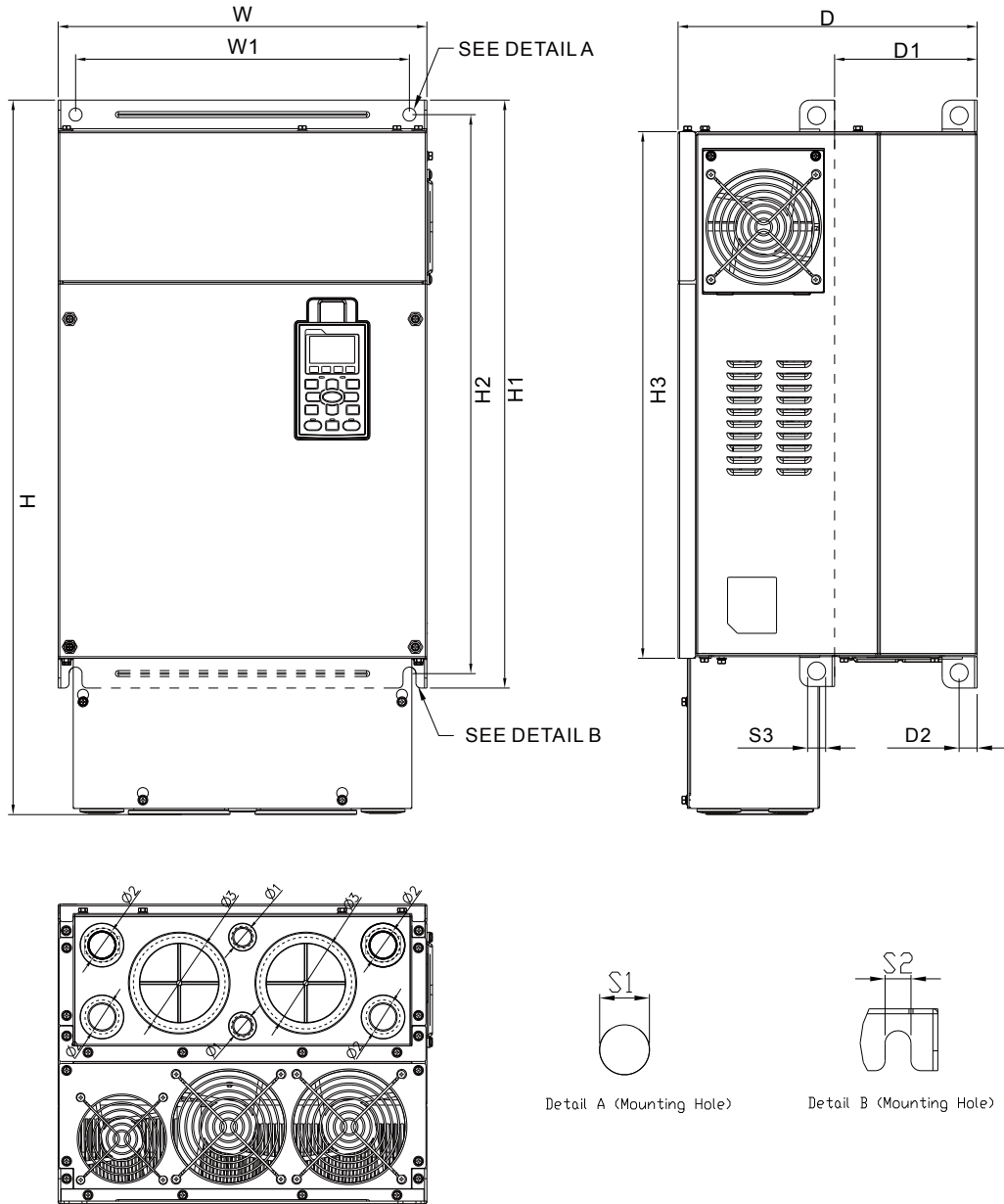

**MODEL**  
**FRAME\_E2**

VFD450C23E	VFD750C63B-21
VFD550C23E	VFD900C63B-21
VFD750C23E	VFD1100C63B-21
VFD900C43E	VFD1320C63B-21
VFD1100C43E	

Frame	W	H	D	W1	H1	H2	H3	D1*	D2	S1	S2	S3	Ø1	Ø2	Ø3	
E2	mm	370.0	715.8	300.0	335.0	589.0	560.0	528.0	143.0	18.0	13.0	13.0	18.0	22.0	34.0	92.0
	inch	14.57	28.18	11.81	13.19	23.19	22.05	20.80	5.63	0.71	0.51	0.51	0.71	0.87	1.34	3.62

\*D1: Flange mount.

# Frame F

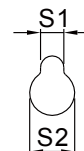
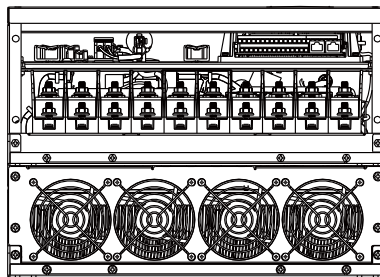
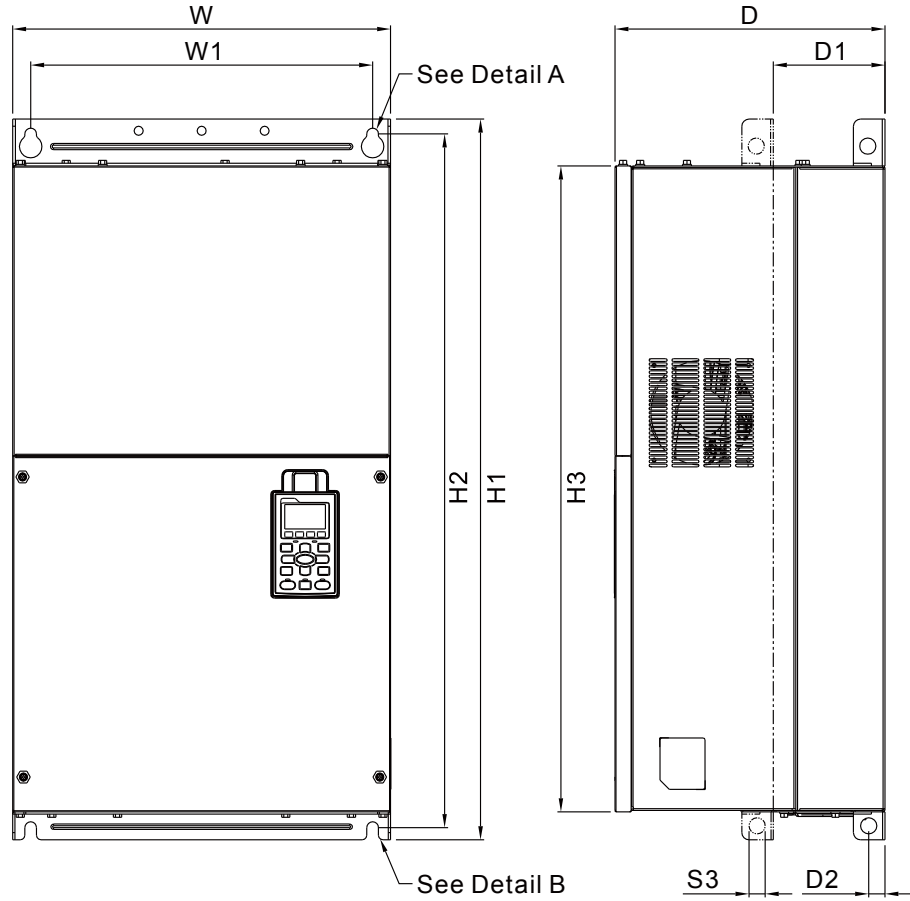

Detail A (Mounting Hole)

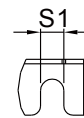

Detail B (Mounting Hole)

**MODEL**  
**FRAME\_F1**

- VFD900C23A
- VFD1320C43A
- VFD1600C43A
- VFD1600C63B-00
- VFD2000C63B-00

Frame	W	H	D	W1	H1	H2	H3	D1*	D2	S1	S2	S3	Ø1	Ø2	Ø3	
F1	mm	420.0	-	300.0	380.0	800.0	770.0	717.0	124.0	18.0	13.0	25.0	18.0	92.0	35.0	22.0
	inch	16.54	-	11.81	14.96	31.50	30.32	28.23	4.88	0.71	0.51	0.98	0.71	3.62	1.38	0.87

\*D1: Flange mount.

# Dimensions

## Frame F

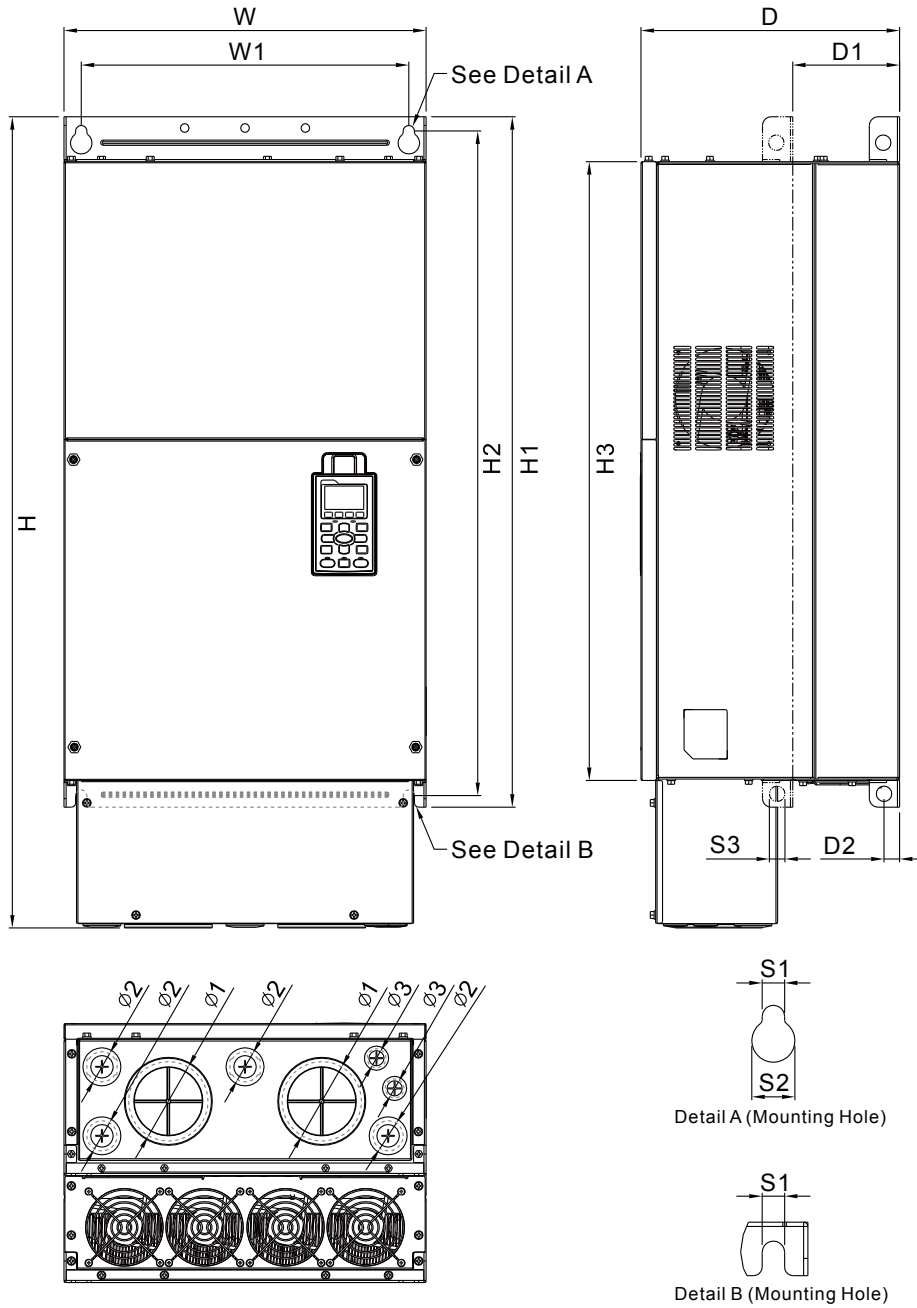

**MODEL**  
**FRAME\_F2**

VFD900C23E  
VFD1320C43E  
VFD1600C43E  
VFD1600C63B-21  
VFD2000C63B-21

Frame		W	H	D	W1	H1	H2	H3	D1*	D2	S1	S2	S3	Ø1	Ø2	Ø3
F2	mm	420.0	940.0	300.0	380.0	800.0	770.0	717.0	124.0	18.0	13.0	25.0	18.0	92.0	35.0	22.0
	inch	16.54	37.00	11.81	14.96	31.50	30.32	28.23	4.88	0.71	0.51	0.98	0.71	3.62	1.38	0.87

\*D1: Flange mount.

# Frame G

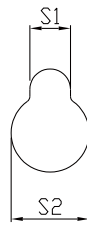
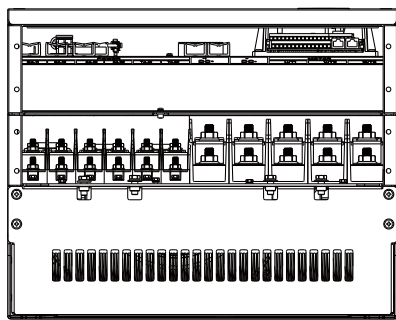
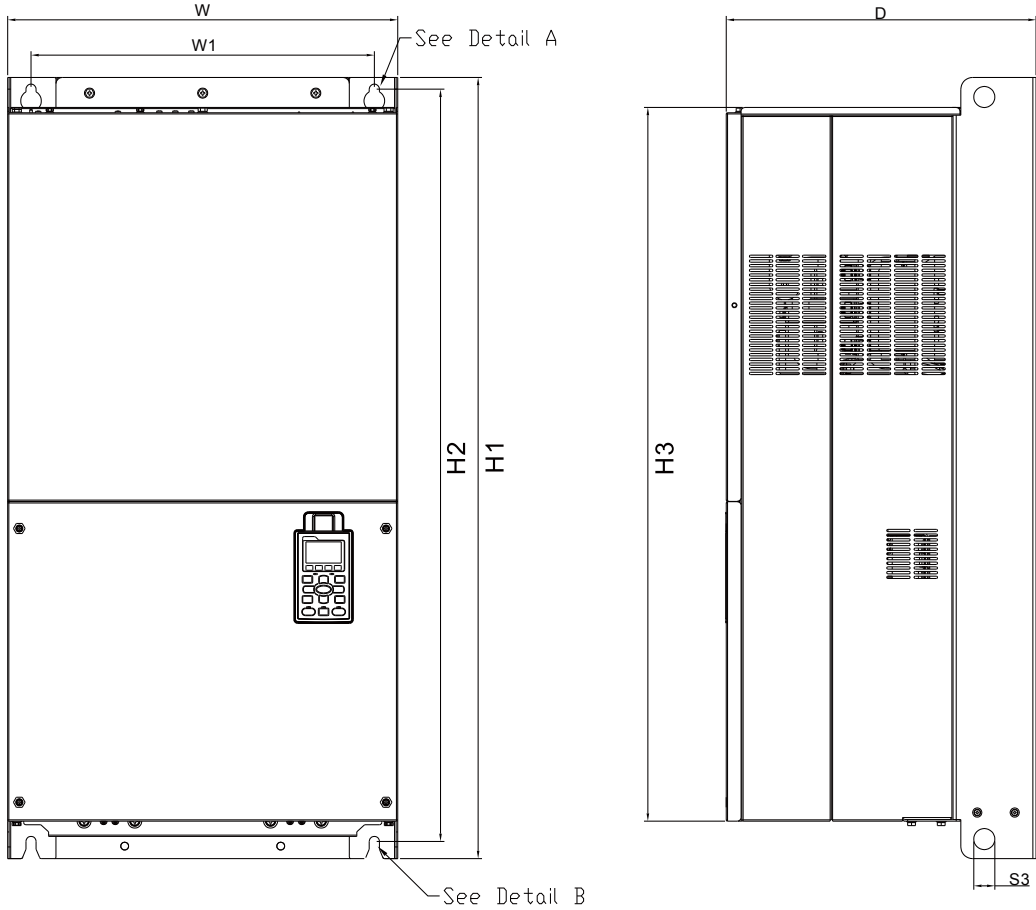

Detail A (Mounting Hole)

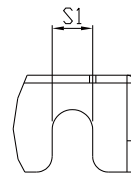

Detail B (Mounting Hole)

## MODEL FRAME\_G1

- VFD1850C43A
- VFD2200C43A
- VFD2500C63B-00
- VFD3150C63B-00

Frame		W	H	D	W1	H1	H2	H3	S1	S2	S3	Ø1	Ø2	Ø3
G1	mm	500.0	-	397.0	440.0	1000.0	963.0	913.6	13.0	26.5	27.0	-	-	-
	inch	19.69	-	15.63	217.32	39.37	37.91	35.97	0.51	1.04	1.06	-	-	-

# Dimensions

## Frame G

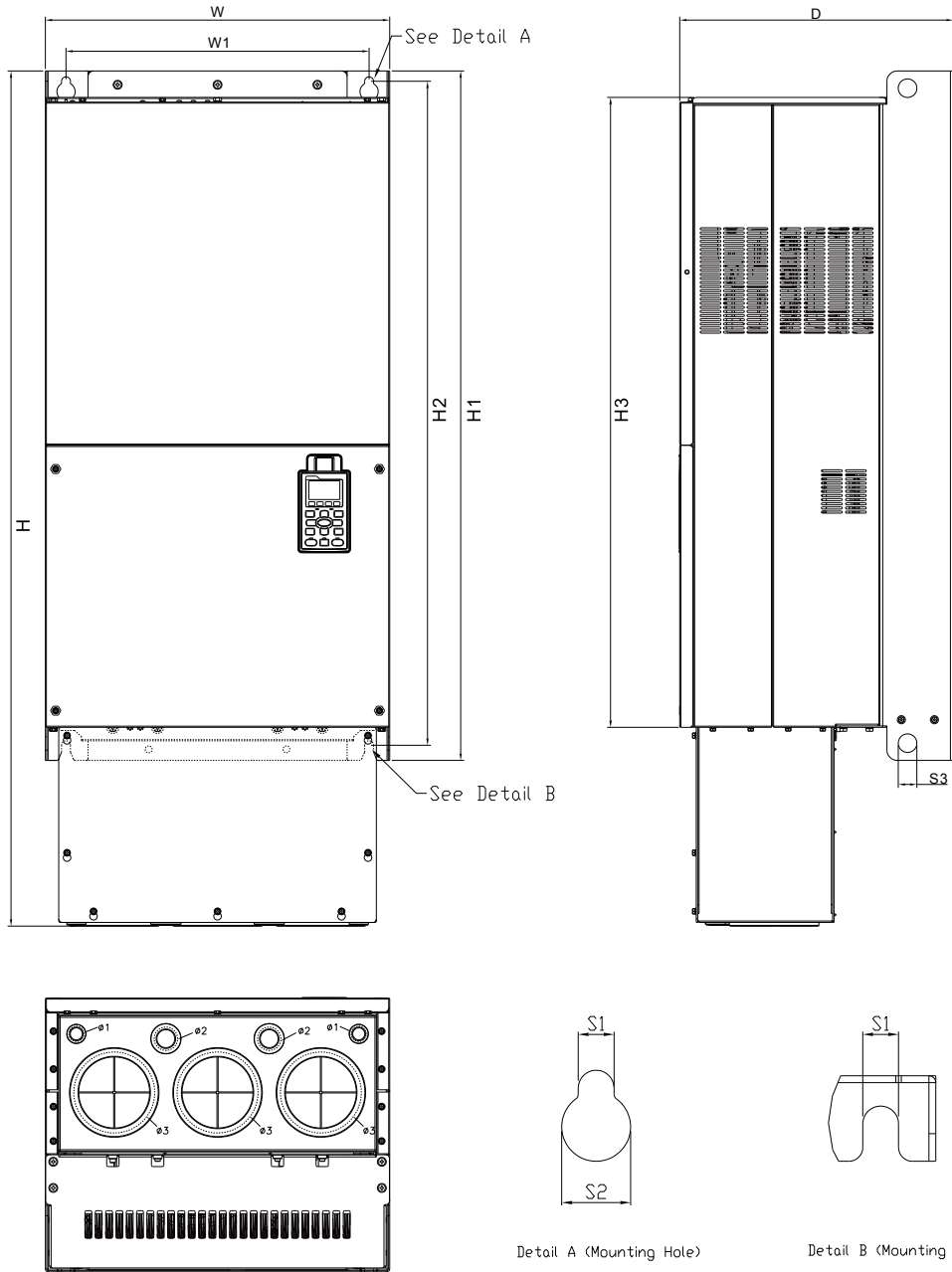

**MODEL**  
**FRAME\_G2**

VFD1850C43E  
VFD2200C43E  
VFD2500C63B-21  
VFD3150C63B-21

Frame	W	H	D	W1	H1	H2	H3	S1	S2	S3	Ø1	Ø2	Ø3	
G2	mm	500.0	1240.2	397.0	440.0	1000.0	963.0	913.6	13.0	26.5	27.0	22.0	34.0	117.5
	inch	19.69	48.83	15.63	217.32	39.37	37.91	35.97	0.51	1.04	1.06	0.87	1.34	4.63

# Frame H1

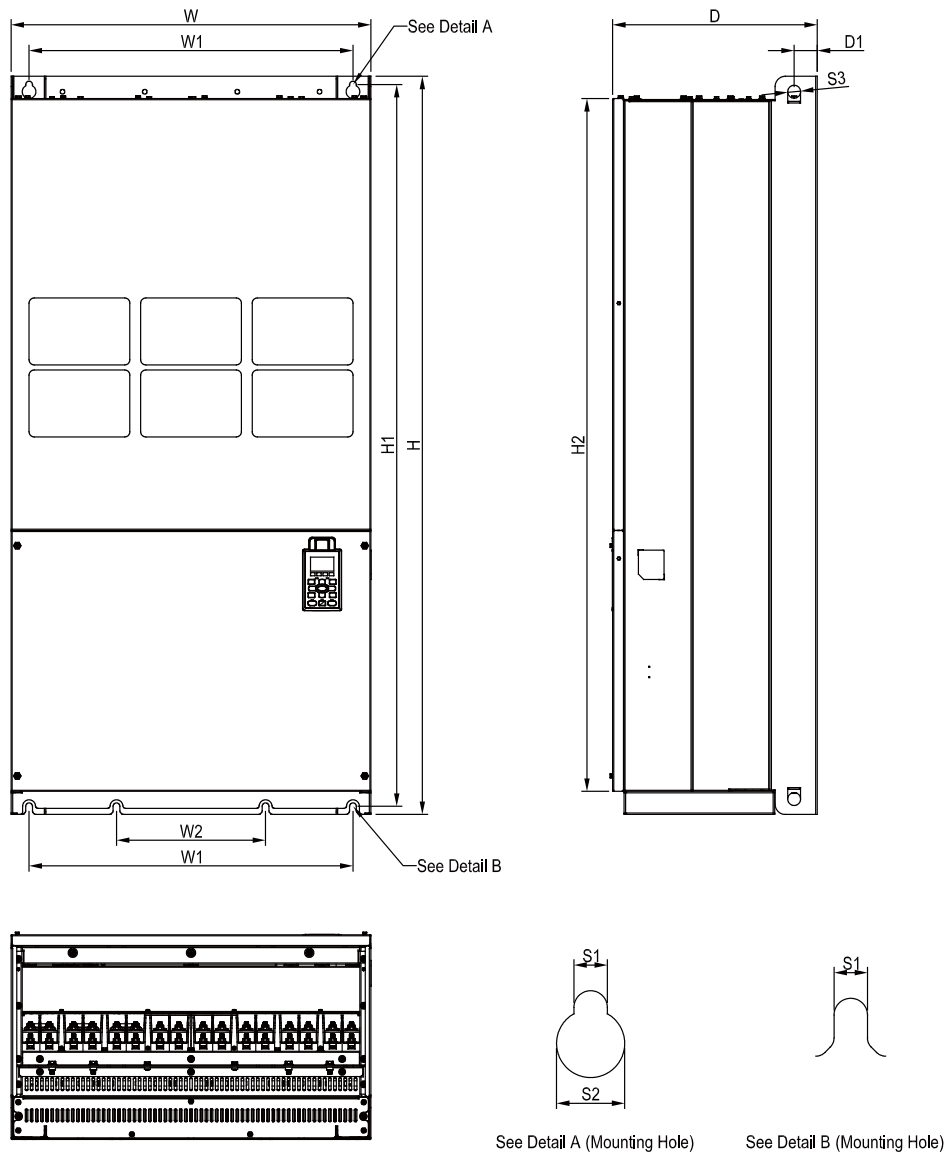

## MODEL FRAME\_H1

VFD2800C43A  
VFD3150C43A  
VFD3550C43A  
VFD4500C43A

Frame	W	H	D	W1	W2	W3	W4	W5	W6	H1	H2	H3	H4
H1	mm	700.0	1435.0	398.0	630.0	290.0	-	-	-	1403.0	1346.6	-	-
	inch	27.56	56.50	15.67	24.80	11.42	-	-	-	55.24	53.02	-	-
Frame	H5	D1	D2	D3	D4	D5	D6	S1	S2	S3	Ø1	Ø2	Ø3
H1	mm	-	45.0	-	-	-	-	13.0	26.5	25.0	-	-	-
	inch	-	1.77	-	-	-	-	0.51	1.04	0.98	-	-	-

# Dimensions

## Frame H2

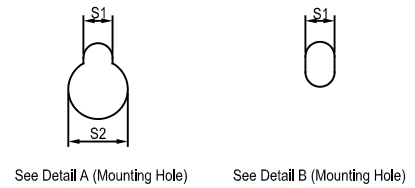
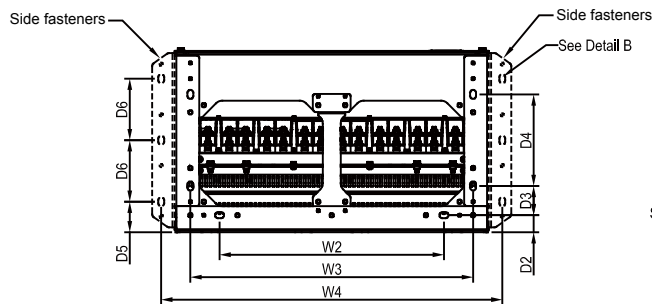
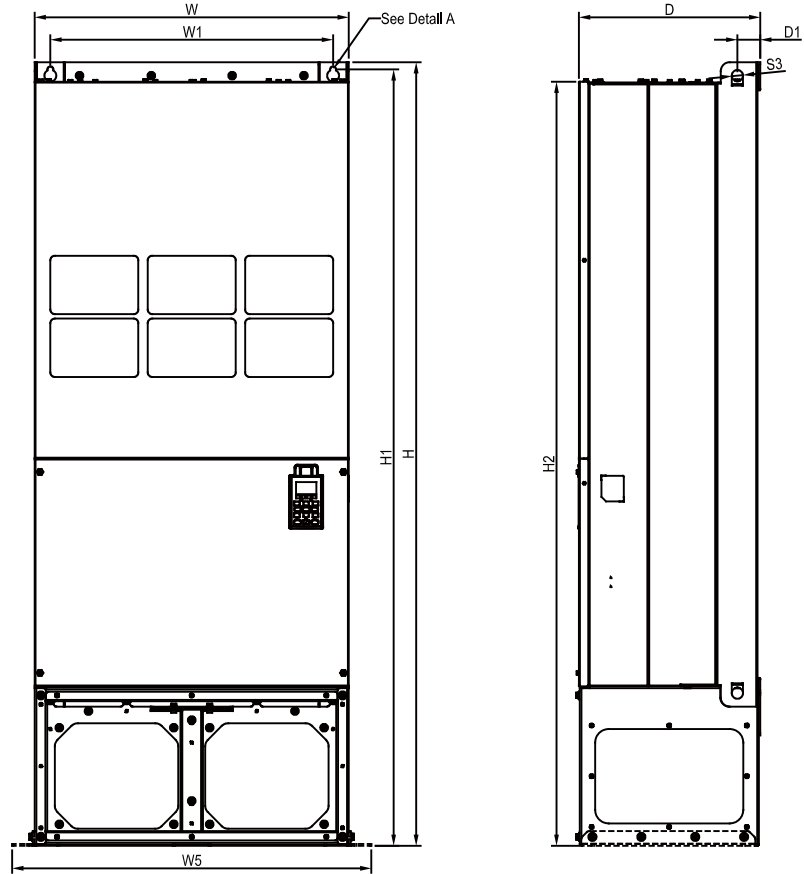

### MODEL FRAME\_H2

VFD2800C43E-1  
VFD3150C43E-1  
VFD3550C43E-1  
VFD4500C43E-1

Frame		W	H	D	W1	W2	W3	W4	W5	W6	H1	H2	H3	H4
H2	mm	700.0	1745.0	404.0	630.0	500.0	630.0	760.0	800.0	-	1729.0	1701.6	-	-
	inch	27.56	68.70	15.9	24.80	19.69	24.80	29.92	31.50	-	68.07	66.99	-	-
Frame		H5	D1	D2	D3	D4	D5	D6	S1	S2	S3	Ø1	Ø2	Ø3
H2	mm	-	51.0	38.0	65.0	204.0	68.0	137.0	13.0	26.5	25.0	-	-	-
	inch	-	2.0	1.50	2.56	8.03	2.68	5.4	0.51	1.04	0.98	-	-	-



# Frame H3

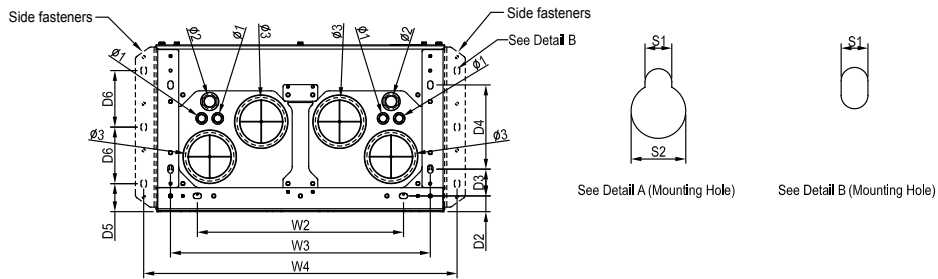
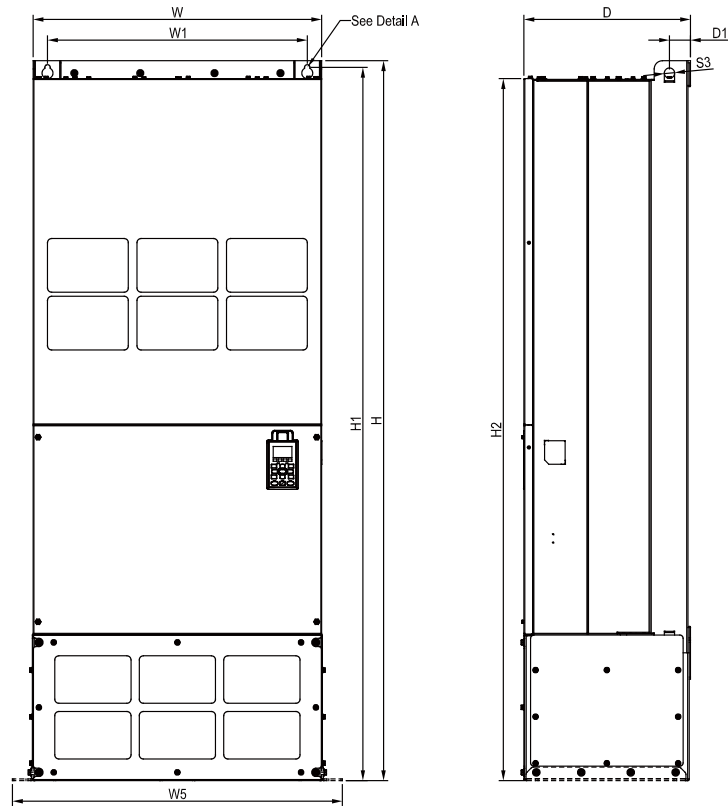

**MODEL**  
**FRAME\_H3**  
 VFD2800C43E  
 VFD3150C43E  
 VFD3550C43E  
 VFD4500C43E

Frame	W	H	D	W1	W2	W3	W4	W5	W6	H1	H2	H3	H4	
H3	mm	700.0	1745.0	404.0	630.0	500.0	630.0	760.0	800.0	-	1729.0	1701.6	-	-
	inch	27.56	68.70	15.9	24.80	19.69	24.80	29.92	31.50	-	68.07	66.99	-	-
Frame	H5	D1	D2	D3	D4	D5	D6	S1	S2	S3	Ø1	Ø2	Ø3	
H3	mm	-	51.0	38.0	65.0	204.0	68.0	137.0	13.0	26.5	25.0	22.0	34.0	117.5
	inch	-	2.0	1.50	2.56	8.03	2.68	5.4	0.51	1.04	0.98	0.87	1.34	4.63

# Dimensions

## 690V Frame H1

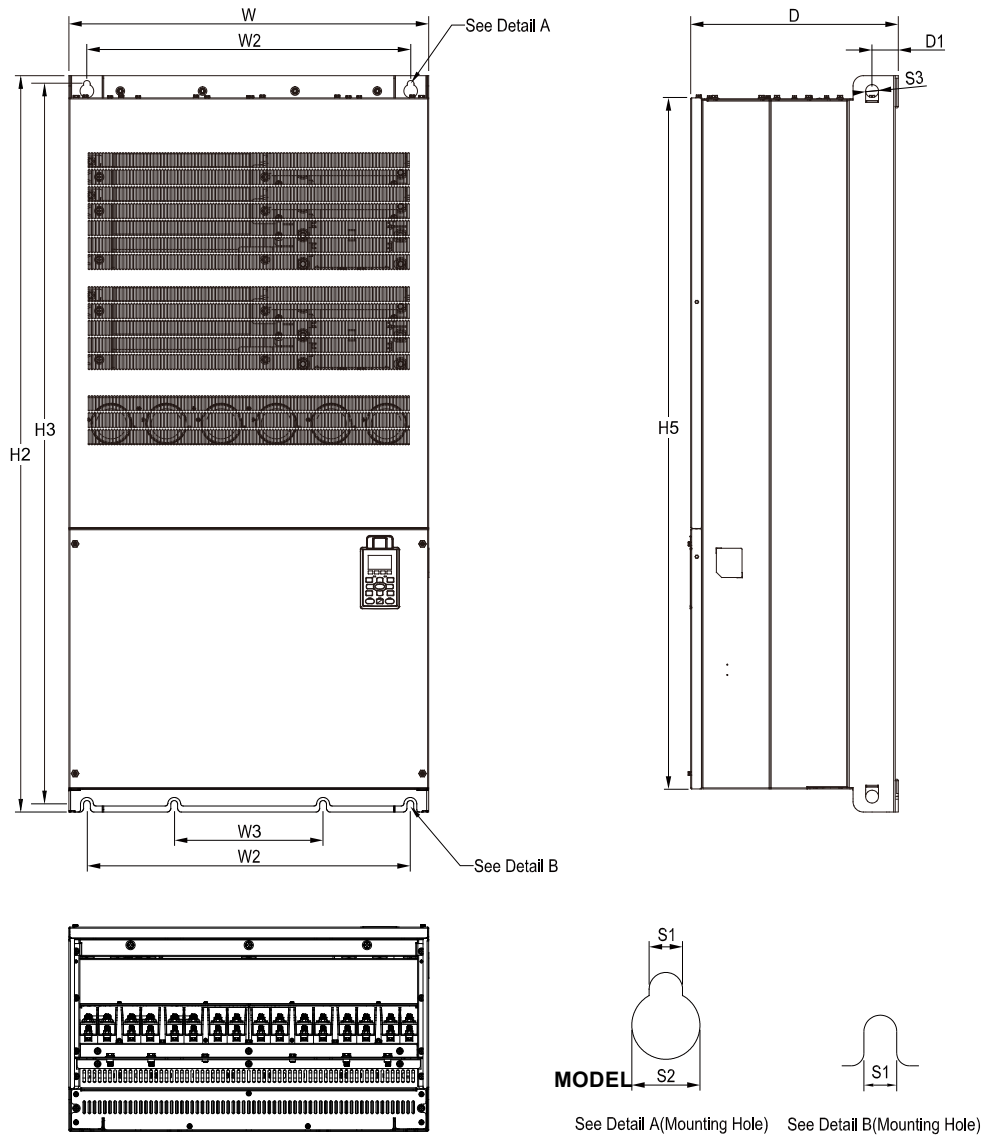

**MODEL**  
**690V FRAME\_H1**

- VFD4000C63B-00
- VFD4500C63B-00
- VFD5600C63B-00
- VFD6300C63B-00

框號	W	H	D	W1	W2	W3	W4	W5	W6	H1	H2	H3	H4
H1	mm	700.0	-	398.0	-	630.0	290.0	-	-	-	1435.0	1403.0	-
	inch	27.56	-	15.67	-	24.80	11.42	-	-	-	56.50	55.24	-
框號	H5	D1	D2	D3	D4	D5	D6	S1	S2	S3	Ø1	Ø2	Ø3
H1	mm	1346.6	45.0	-	-	-	-	13.0	26.5	25.0	-	-	-
	inch	53.02	1.77	-	-	-	-	0.51	1.04	0.98	-	-	-

# 690 V Frame H2

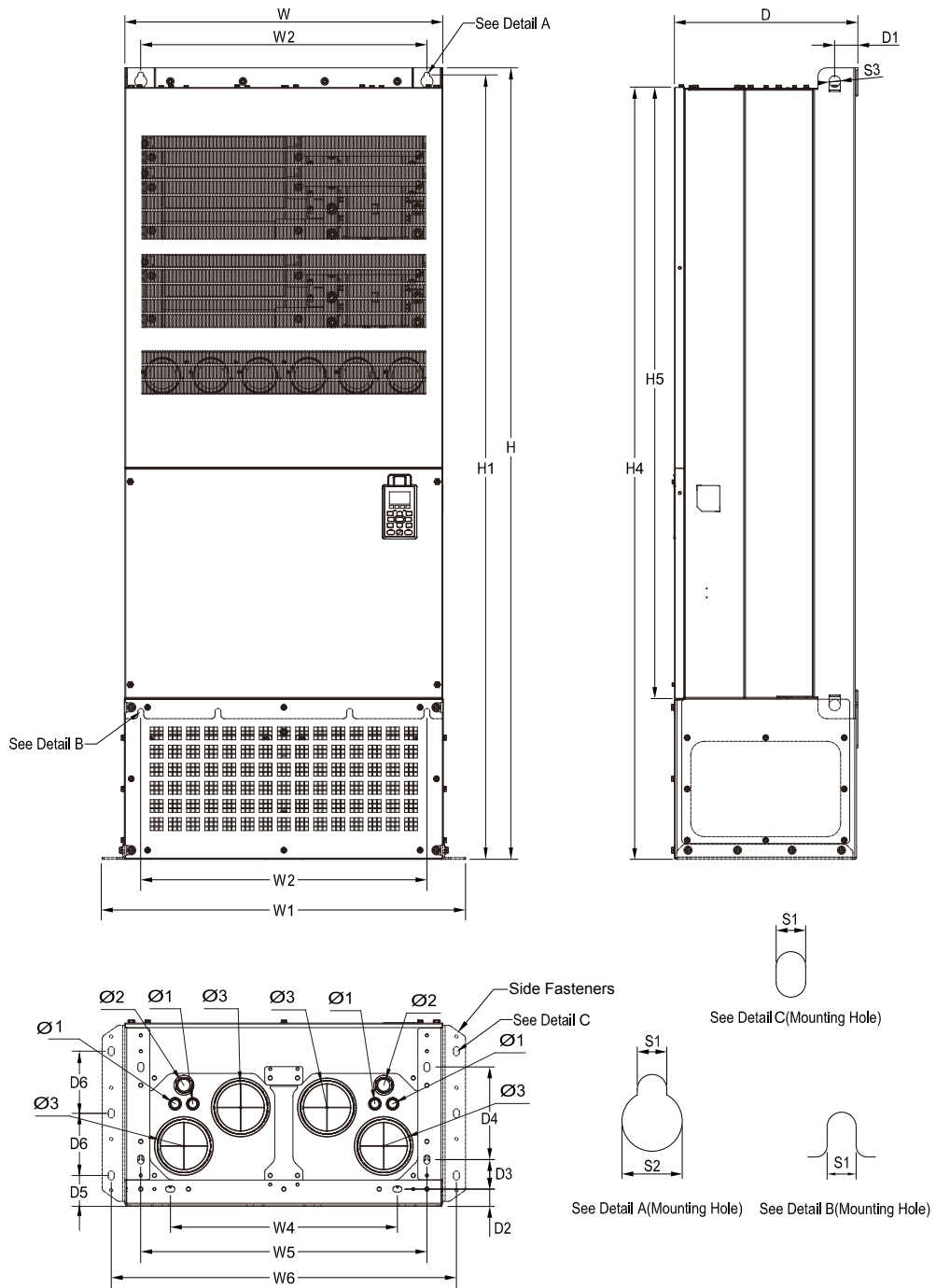

**MODEL**  
**690V FRAME\_H2**

- VFD4000C63B-21
- VFD4500C63B-21
- VFD5600C63B-21
- VFD6300C63B-21

框號	W	H	D	W1	W2	W3	W4	W5	W6	H1	H2	H3	H4	
H3	mm	700.0	1745.0	404.0	800.0	630.0	-	500.0	630.0	760.0	1729.0	-	-	1701.6
	inch	27.56	68.70	15.91	31.50	24.80	-	19.69	24.80	29.92	68.07	-	-	66.99
框號	H5	D1	D2	D3	D4	D5	D6	S1	S2	S3	Ø1	Ø2	Ø3	
H3	mm	1346.6	51.0	38.0	65.0	204.0	68.0	137.0	13.0	26.5	25.0	22.0	34.0	117.5
	inch	53.02	2.01	1.50	2.56	8.03	2.68	5.39	0.51	1.04	0.98	0.87	1.34	4.63

# Accessories

## EMC-PG01L / EMC-PG02L

		Terminals	Description
 <p>Set by Pr.10-00 ~ 10-02</p>	PG1	VP	Output voltage for power: +5V/+12V ± 5% (use FSW3 to switch +5V/+12V) Max. output current: 200 mA
		DCM	Common for power and signal
		A1, /A1, B1, /B1, Z1, /Z1	Encoder input signal (Line Driver) Open collector input: +5 V / +24 V (Note1) 1-phase or 2-phase input Max. input frequency: EMC-PG01L: 300KHz; EMC-PG02L: 30KHz
	PG2	A2, /A2, B2, /B2	Pulse input signal (Line Driver or Open Collector) Open collector input: +5V/+24V (Note1) 1-phase or 2-phase input Max. input frequency: EMC-PG01L: 300KHz; EMC-PG02L: 30KHz
	PG OUT	AO, /AO, BO, /BO, ZO, /ZO, SG	PG card output signals. Division frequency function: 1 ~ 255 times Max. output voltage for Line driver: 5V <sub>DC</sub> Max. output current: 50 mA Max. output frequency: EMC-PG01L: 300KHz; EMC-PG02L: 30KHz SG: The GND of PG card is the same as the host controller or PLC, so a common output signal is attained.

## EMC-PG01O / EMC-PG02O

		Terminals	Description
 <p>Set by Pr.10-00 ~ 10-02</p>	PG1	VP	Output voltage for power: +5V/+12V ± 5% (use FSW3 to switch +5V/+12V) Max. output current: 200 mA
		DCM	Common for power and signal
		A1, /A1, B1, /B1, Z1, /Z1	Encoder input signal (Line Driver or Open Collector) Open collector input: +5V/+24V (Note1) 1-phase or 2-phase input Max. input frequency: EMC-PG01O: 300KHz; EMC-PG02O: 30KHz
	PG2	A2, /A2, B2, /B2	Pulse input signal (Line Driver or Open Collector) Open collector input: +5V/+24V (Note1) 1-phase or 2-phase input Max. input frequency: EMC-PG01O: 300KHz; EMC-PG02O: 30KHz
	PG OUT	V+, /V- V- A/O, B/O, ZO,	Needs external power source for PG OUT circuit. Input voltage of power: +12V ~ +24V Negative power supply input PG card output signals. Division frequency function: 1 ~ 255 times Add a pull-up resistor to the open collector output signals to avoid signal interferences. [Three pull-up resistors are included in the package (1.8KΩ/1W)] Max. Output current: 20 mA Max output frequency: EMC-PG01O: 300KHz; EMC-PG02O: 30KHz

## EMC-PG01R

		Terminals	Description
 <p>Set by Pr.10-00 ~ 10-02</p>	PG1	R1- R2	Resolver output power 7V <sub>rms</sub> , 10kHz
		S1, S2, S3, S4 S4,	Resolver input signal 3.5 ± 0.175V <sub>rms</sub> , 10kHz
	PG2	A2, /A2, B2, /B2	Pulse input signal (Line Driver or Open Collector) Open collector input: +5V/+24V (Note1) 1-phase or 2-phase input; Max. input frequency: 300KHz
	PG OUT	AO, /AO, BO, /BO, ZO, /ZO, SG	PG card output signals. Division frequency function: 1 ~ 255 times Max. output voltage for Line driver: 5V <sub>DC</sub> Max. output current: 50 mA Max. output frequency: 300 KHz SG: The GND of PG card is the same as the host controller or PLC, so a common output signal is attained.

▪ EMC-PG01U / EMC-PG02U

FJMP1 : Standard UVW Output Encoder; : Delta Encoder



Set by Pr.10-00 ~ 10-02

Terminals	Description
PG1	VP Output voltage for power: +5V/+12V ± 5% (use FSW3 to switch +5V/+12V) Max. output current: 200mA
	DCM Common for power and signal
	A1, /A1, B1, /B1, Z1, /Z1 Encoder input signal (Line Driver) 1-phase or 2-phase input. Max. input frequency: 300 KHz
	U1, /U1, V1, /V1, W1, /W1 Encoder input signal
PG2	A2, /A2, B2, /B2 Pulse input signal Open collector input: +5V/+24V (Note1) 1-phase or 2-phase input; Max. input frequency: 300KHz
PG OUT	AO, /AO, BO, /BO, ZO, /ZO, SG PG card output signals. Division frequency function: 1 ~ 255 times Max. output voltage for Line driver: 5V <sub>DC</sub> Max. output current: 50 mA Max. output frequency: 300 KHz SG: The GND of PG card is the same as the host controller or PLC, so a common output signal is attained.

Note 1: For the Open Collector, set input voltage to 5 ~ 15 mA and install a pull-up resistor  
 [5 V] Recommend pull-up resistor: 100 ~ 220Ω, 1/2 W and above  
 [12 V] Recommend pull-up resistor: 510 ~ 1.35 KΩ, 1/2 W and above  
 [24 V] Recommend pull-up resistor: 1.8K ~ 3.3 KΩ, 1/2 W and above

▪ EMC-D42A



I/O Extension Card

Terminals	Description
COM	Common for multi-function input terminals Select SINK (NPN)/SOURCE (PNP) in J1 jumper/external power supply
MI10 ~ MI13	Refer to parameters 02-26 ~ 02-29 to program the multi-function inputs MI10 ~ MI13. Internal power is applied from terminal E24: +24 V <sub>DC</sub> ± 5% 200 mA, 5 W External power +24 V <sub>DC</sub> : max. voltage 30 V <sub>DC</sub> , min. voltage 19 V <sub>DC</sub> , 30 W ON: the activation current is 6.5 mA; OFF: leakage current tolerance is 10 μA
MO10 ~ MO11	Multi-function output terminals (photocoupler) Duty-cycle: 50%; Max. output frequency: 100 Hz Max. current: 50 mA; Max. voltage: 48 V <sub>DC</sub>
MXM	Common for multi-function output terminals MO10, MO11 (photocoupler) Max 48 V <sub>DC</sub> 50 mA

▪ EMC-D611A



I/O Extension Card

Terminals	Description
AC	AC power common for multi-function input terminal (Neutral)
MI10 ~ MI15	Refer to Pr. 02.26 ~ Pr. 02.31 for multi-function input selection Input voltage: 100 ~ 130 V <sub>AC</sub> ; Input frequency: 57 ~ 63 Hz Input impedance: 27 KΩ Terminal response time: ON: 10 ms; OFF: 20 ms

## Screw Specifications for Option Card Terminals

EMC-D42A/EMC-D611A EMC-BPS01	Wire gauge	24 ~ 12AWG (0.205 ~ 3.31 mm <sup>2</sup> )
	Torque	4 Kg-cm [3.47 lb-in]
EMC-R6AA	Wire gauge	24 ~ 16AWG (0.205 ~ 1.31 mm <sup>2</sup> )
	Torque	6 Kg-cm [5.21 lb-in]
EMC-PG01L/EMC-PG01O EMC-PG01R/	Wire gauge	30 ~ 16AWG (0.0509 ~ 1.31 mm <sup>2</sup> )
	Torque	2 Kg-cm [1.74 lb-in]

# Accessories

## EMC-R6AA

	Terminals	Description
 <p>Relay Extension Card</p>	<p>RA10 ~ RA15 RC10 ~ RC15</p>	<p>Refer to Pr. 02.36 ~ Pr. 02.41 for multi-function input selection</p> <p>Resistive load: 3A (N.O.) / 250 V<sub>AC</sub> 5A (N.O.) / 30 V<sub>DC</sub></p> <p>Inductive load (COS 0.4) 2.0A (N.O.) / 250 V<sub>AC</sub> 2.0A (N.O.) / 30 V<sub>DC</sub></p> <p>It is used to output each monitor signal, such as for drive in operation, frequency attained or overload indication.</p>

## EMC-BPS01

	Terminals	Description
 <p>24V Power Shift Card</p>	<p>24V GND</p>	<p>When the AC motor drive power is off, the external power supply card provides external power to the network system, PLC function, and other functions to allow continued operations.</p> <p>Input power: 24 V<sub>DC</sub> ±5% Maximum input current: 0.5A</p> <p>Note: Do not connect the control terminal +24V (Digital control signal common: SOURCE) directly to the EMC-BPS01 input terminal 24V. Do not connect control terminal GND directly to the EMC-BPS01 input terminal GND.</p>

## CMC-MOD01

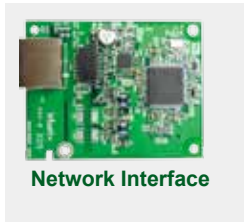

### Features

- ▶ MDI/MDI-X auto-detect
- ▶ Supports MODBUS TCP protocol
- ▶ AC motor drive keypad/Ethernet configuration
- ▶ E-mail alarm
- ▶ Baud rate: 10/100 Mbps auto-detect
- ▶ Virtual serial port

### Network Interface

Interface	RJ-45 with Auto MDI/MDIX	Transmission speed	10/100 Mbps Auto-Detect
Number of ports	1 Port	Network protocol	ICMP, IP, TCP, UDP, DHCP, SMTP, MODBUS over TCP/IP, Delta Configuration
Transmission method	IEEE 802.3, IEEE 802.3u		
Transmission cable	Category 5e shielding 100 M		

## CMC-EIP01



### Features

- ▶ MDI/MDI-X auto-detect
- ▶ Supports MODBUS TCP and Ethernet/IP protocol
- ▶ Baud rate: 10/100 Mbps auto-detect
- ▶ AC motor drive keypad/Ethernet configuration
- ▶ Virtual serial port

### Network Interface

Interface	RJ-45 with Auto MDI/MDIX	Transmission speed	10/100 Mbps Auto-Detect
Number of ports	1 Port	Network protocol	ICMP, IP, TCP, UDP, DHCP, SMTP, MODBUS over TCP/IP, Delta Configuration
Transmission method	IEEE 802.3, IEEE 802.3u		
Transmission cable	Category 5e shielding 100 M		

## ▪ CMC-PD01



### Features

- ▶ Supports PZD control data exchange
- ▶ Supports PKW polling AC motor drive parameters
- ▶ Supports user diagnosis function
- ▶ Auto-detects baud rates; supports Max. 12Mbps

### PROFIBUS DP Connector

<b>Interface</b>	DB9 connector
<b>Transmission method</b>	High-speed RS-485
<b>Transmission cable</b>	Shielded twisted pair cable
<b>Electrical isolation</b>	500V <sub>DC</sub>

### Communication

<b>Message type</b>	Cyclic data exchange
<b>Module name</b>	CMC-PD01
<b>GSD document</b>	DELA08DB.GSD
<b>Company ID</b>	08DB (HEX)
<b>Serial transmission speed supported (auto-detection)</b>	9.6 kbps; 19.2 kbps; 93.75 kbps; 187.5 kbps; 125 kbps; 250 kbps; 500 kbps; 1.5 Mbps; 3 Mbps; 6 Mbps; 12 Mbps (bits per second)

## ▪ CMC-DN01



### Features

- ▶ Based on the high-speed communication interface of Delta HSSP protocol, able to conduct immediate control of an AC motor drive
- ▶ Supports Group 2 only connection and polling I/O data exchange
- ▶ For I/O mapping, supports Max. 32 words of input and 32 words of output
- ▶ Supports EDS file configuration in DeviceNet configuration software
- ▶ Supports all baud rates on DeviceNet bus: 125 kbps, 250 kbps, 500 kbps and extendable serial transmission speed mode
- ▶ Node address and serial transmission speed can be set up on AC motor drive
- ▶ Power supplied from AC motor drive

### DeviceNet Connector

<b>Interface</b>	5-Pin 5.08mm pluggable connector
<b>Transmission method</b>	CAN
<b>Transmission cable</b>	Shielded twisted pair cable (with 2 power cables)
<b>Transmission speed</b>	125 kbps, 250 kbps, 500 kbps and extendable serial transmission speed mode
<b>Network protocol</b>	DeviceNet protocol

### DeviceNet Connector

<b>Interface</b>	50 PIN communication terminal
<b>Transmission method</b>	SPI communication
<b>Terminal function</b>	1. Communicating with AC motor drive 2. Transmitting power supply from AC motor drive
<b>Communication protocol</b>	Delta HSSP protocol

## ▪ EMC-COP01

Built-in EMC-COP01 card are available for VFDXXXC23E and VFDXXXC43E

### RJ-45 Pin definition

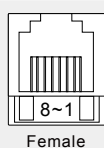
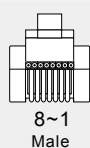

Pin	Pin name	Definition
1	CAN_H	CAN_H bus line (dominant high)
2	CAN_L	CAN_L bus line (dominant low)
3	CAN_GND	Ground/0V/V-
6	CAN_GND	Ground/0V/V-

# Model Name

- 230V / 460V:

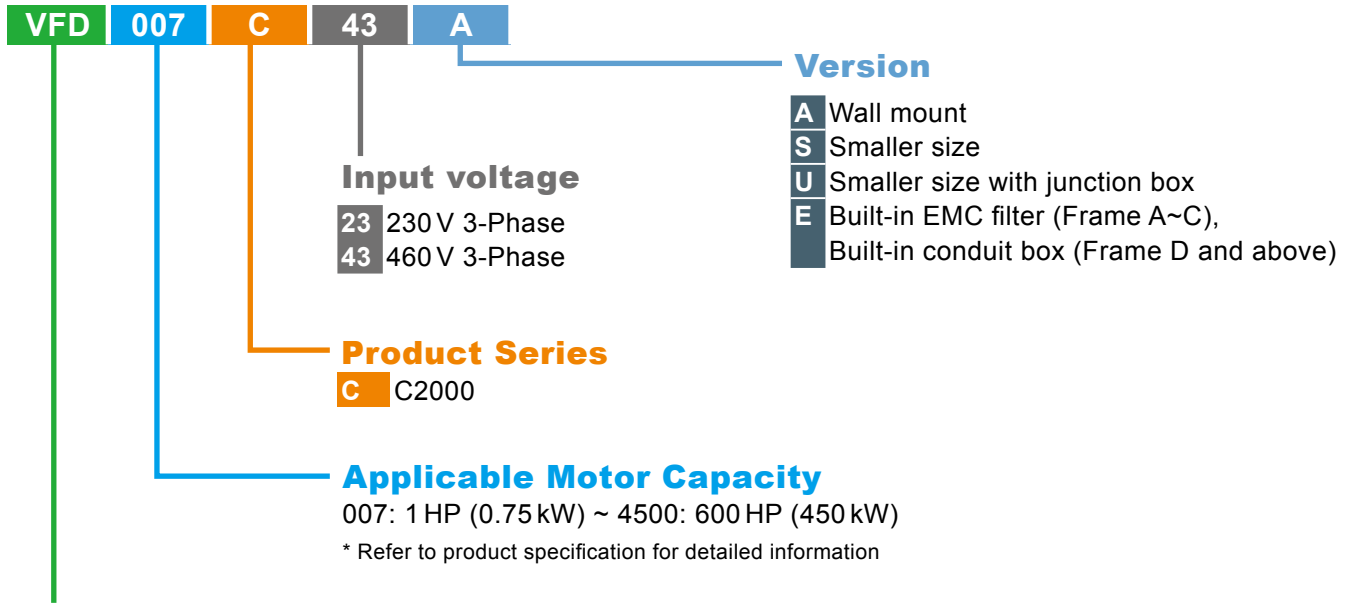

**Series Name**  
Variable Frequency Drive

- 575V / 690V:

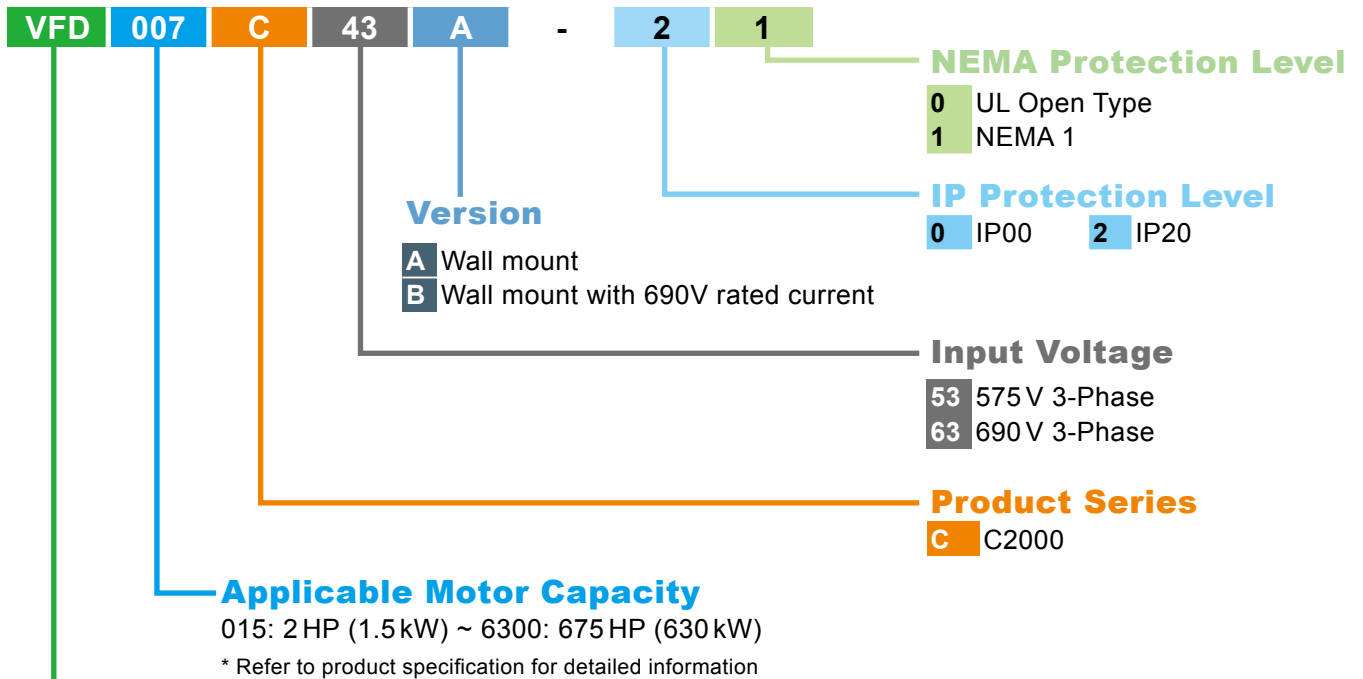

**Series Name**  
Variable Frequency Drive



# Accessories

## CANopen Communication Cable

Model: TAP-CB05, TAP-CB10

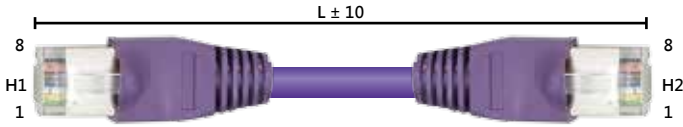

Title	Part No.	L	
		mm	inch
1	UC-CMC003-01A	300	11.8
2	UC-CMC005-01A	500	19.6
3	UC-CMC010-01A	1000	39
4	UC-CMC015-01A	1500	59
5	UC-CMC020-01A	2000	78.7
6	UC-CMC030-01A	3000	118.1
7	UC-CMC050-01A	5000	196.8
8	UC-CMC100-01A	10000	393.7
9	UC-CMC200-01A	20000	787.4

## Digital Keypad Accessories: RJ45 Extension Leads and CMC-EIP01 Cables

Applicable Models: CBC-K3FT, CBC-K5FT, CBC-K7FT, CBC-K10F, CBC-K16FT

Title	Part No.	Explanation
1	CBC-K3FT	RJ45 extension lead, 3 feet (approximately 0.9m)
2	CBC-K5FT	RJ45 extension lead, 5 feet (approximately 1.5m)
3	CBC-K7FT	RJ45 extension lead, 7 feet (approximately 2.1m)
4	CBC-K10FT	RJ45 extension lead, 10 feet (approximately 3m)
5	CBC-K16FT	RJ45 extension lead, 16 feet (approximately 4.9m)

# Ordering Information

Frame Size	Power Range	Models				
<b>Frame A</b> 	230 V: 0.75~3.7 kW  460 V: 0.75~5.5 kW  575 V: 1.5~3.7 kW	VFD007C 23A VFD015C 23A VFD022C 23A VFD037C 23A	VFD007C 43A VFD015C 43A VFD022C 43A VFD037C 43A VFD040C 43A VFD055C 43A	VFD007C 43E VFD015C 43E VFD022C 43E VFD037C 43E VFD040C 43E VFD055C 43E	VFD015C53A-21 VFD022C53A-21 VFD037C53A-21	
<b>Frame B</b> 	230 V: 5.5~11 kW  460 V: 7.5~15 kW  575 V: 5.5~15 kW	VFD055C 23A VFD075C 23A VFD110C 23A	VFD075C 43A VFD110C 43A VFD150C 43A	VFD075C 43E VFD110C 43E VFD150C 43E	VFD055C53A-21 VFD075C53A-21 VFD110C53A-21 VFD150C53A-21	
<b>Frame C</b> 	230 V: 15~22 kW  460 V: 18.5~30 kW  690 V: 18.5~37 kW	VFD150C 23A VFD185C 23A VFD220C 23A	VFD185C 43A VFD220C 43A VFD300C 43A	VFD185C 43E VFD220C 43E VFD300C 43E	VFD185C63B-21 VFD220C63B-21 VFD300C63B-21 VFD370C63B-21	
<b>Frame D</b> 	230 V: 30~37 kW  460 V: 37~75 kW  690 V: 55~75 kW	<b>Frame D1</b> VFD300C 23A VFD370C 23A VFD550C 23A VFD750C 23A VFD450C63B-00 VFD550C63B-00	<b>Frame D0-1</b> VFD370C 43S VFD450C 43S	<b>Frame D2</b> VFD300C 23E VFD370C 23E VFD550C 43E VFD750C 43E VFD450C63B-21 VFD550C63B-21	<b>Frame D0-2</b> VFD370C 43U VFD450C 43U	

# Ordering Information

Frame Size		Power Range	Models		
<b>Frame E</b>		230 V: 45 ~ 75 kW  460 V: 90 ~ 110 kW  690 V: 75 ~ 132 kW	<b>Frame_E1</b> VFD450C 23A VFD550C 23A VFD750C 23A VFD900C 43A VFD1100C 43A VFD750C63B-00 VFD900C63B-00 VFD1100C63B-00 VFD1320C63B-00	<b>Frame_E2</b> VFD450C 23E VFD550C 23E VFD750C 23E VFD900C 43E VFD1100C 43E VFD750C63B-21 VFD900C63B-21 VFD1100C63B-21 VFD1320C63B-21	
<b>Frame F</b>		230 V: 90 kW  460 V: 132 ~ 160 kW  690 V: 160 ~ 200 kW	<b>Frame_F1</b> VFD900C 23A VFD1320C 43A VFD1600C 43A VFD1600C63B-00 VFD2000C63B-00	<b>Frame_F2</b> VFD900C 23E VFD1320C 43E VFD1600C 43E VFD1600C63B-21 VFD2000C63B-21	
<b>Frame G</b>		460 V: 185 ~ 220 kW  690 V: 250 ~ 315 kW	<b>Frame_G1</b> VFD1850C 43A VFD2200C 43A VFD2500C63B-00 VFD3150C63B-00	<b>Frame_G2</b> VFD1850C 43E VFD2200C 43E VFD2500C63B-21 VFD3150C63B-21	
<b>Frame H</b>		460 V: 280 ~ 450 kW	<b>Frame_H1</b> VFD2800C 43A VFD3150C 43A VFD3550C 43A VFD4500C 43A	<b>Frame_H2</b> VFD2800C 43E-1 VFD3150C 43E-1 VFD3550C 43E-1 VFD4500C 43E-1	<b>Frame_H3</b> VFD2800C 43E VFD3150C 43E VFD3550C 43E VFD4500C 43E
<b>Frame H (690 V Model)</b>		690 V: 400 ~ 630 kW	<b>Frame_H1</b> VFD4000C63B-00 VFD4500C63B-00 VFD5600C63B-00 VFD6300C63B-00	<b>Frame_H2</b> VFD4000C63B-21 VFD4500C63B-21 VFD5600C63B-21 VFD6300C63B-21	



## Attention

### Standard Motors

#### Output reactor

Please refer to manual to use the output AC reactor when the output cable is long.

#### Torque Characteristics and Temperature Rise

When a standard motor is drive controlled, the motor temperature will be higher than with DOL operation.

Please reduce the motor output torque when operating at low speeds to compensate for less cooling efficiency.

For continuous constant torque at low speeds, external forced motor cooling is recommended.

#### Vibration

When the motor drives the machine, resonances may occur, including machine resonances.

Abnormal vibration may occur when operating a 2-pole motor at 60Hz or higher.

#### Noise

When a standard motor is drive controlled, the motor noise will be higher than with DOL operation.

To lower the noise, please increase the carrier frequency of the drive. The motor fan can be very noisy when the motor speed exceeds 60Hz.

### Special Motors

#### High-speed Motor

To ensure safety, please try the frequency setting with another motor before operating the high-speed motor at 120Hz or higher.

#### Explosion-proof Motor

Please use a motor and drive that comply with explosion-proof requirements.

#### Submersible Motor & Pump

The rated current is higher than that of a standard motor.

Please check before operation and select the capacity of the AC motor drive carefully. The motor temperature characteristics differ from a standard motor, please set the motor thermal time constant to a lower value.

#### Brake Motor

When the motor is equipped with a mechanical brake, the brake should be powered by the mains supply.

Damage may occur when the brake is powered by the drive output. Please DO NOT drive the motor with the brake engaged.

#### Gear Motor

In gearboxes or reduction gears, lubrication may be reduced if the motor is continuously operated at low speeds.

Please DO NOT operate in this way.

#### Synchronous Motor

These motors need suitable software for control. Please contact Delta for more information.

#### Single-phase Motor

Single-phase motors are not suitable for being operated by an AC Motor Drive. Please use a 3-phase motor instead when necessary.

### Environmental Conditions

#### Installation Position

1. The drive is suitable for installation in a place with ambient temperature from  $-10^{\circ}\text{C}$  to  $50^{\circ}\text{C}$ .
2. The surface temperature of the drive and brake resistor will rise under specific operation conditions. Therefore, please install the drive on materials that are noncombustible.
3. Ensure that the installation site complies with the ambient conditions as stated in the manual.

### Wiring

#### Limit of Wiring Distance

For the remote operation, please use twist-shielding cable and the distance between the drive and control box should be less than 20m.

#### Maximum Motor Cable Length

Motor cables that are too long may cause overheating of the drive or current peaks due to stray capacitance. Please ensure that the motor cable is less than 30m.

If the cable length can't be reduced, please lower the carrier frequency or use an AC reactor.

#### Choose the Right Cable

Please refer to current value to choose the right cable section with enough capacity or use recommended cables.

#### Grounding

Please ground the drive completely by using the grounding terminal.

### How to Choose the Drive Capacity

#### Standard Motor

Please select the drive according to applicable motor rated current listed in the drive specification.

Please select the next higher power AC drive in case higher starting torque or quick acceleration/deceleration is needed.

#### Special Motor

Please select the drive according to: Rated current of the drive > rated current of the motor

### Transportation and Storage

Please transport and store the drive in a place that meets environment specifications.

### Peripheral Equipment

#### Molded-Case Circuit Breakers (MCCB)

Please install the recommended MCCB or ELCB in the main circuit of the drive and make sure that the capacity of the breaker is equal to or lower than the recommended one.

#### Add a Magnetic Contactor(MC) in the Output Circuit

When a MC is installed in the output circuit of the drive to switch the motor to commercial power or other purposes, please make sure that the drive and motor are completely stopped and remove the surge absorbers from the MC before switching it.

#### Add a Magnetic Contactor (MC) in the Input Circuit

Please only switch the MC ONCE per hour or it may damage the drive. Please use RUN/STOP signal to switch many times during motor operation.

#### Motor Protection

The thermal protection function of the drive can be used to protect the motor by setting the operation level and motor type (standard motor or variable motor). When using a high-speed motor or a water-cooled motor the thermal time constant should be set to a lower value.

When using a longer cable to connect the motor thermal relay to a motor, high-frequency currents may enter via the stray capacitance. It may result in malfunctioning of the relay as the real current is lower than the setting of thermal relay. Under this condition, please lower the carrier frequency or add an AC reactor to solve this.

#### DO NOT Use Capacitors to Improve the Power Factor

Use a DC reactor to improve the power factor of the drive. Please DO NOT install power factor correction capacitors on the main circuit of the drive to prevent motor faults due to over current.

#### Do NOT Use Surge Absorber

Please DO NOT install surge absorbers on the output circuit of the drive.

#### Lower the Noise

To ensure compliance with EMC regulations, usually a filter and shielded wiring is used to lower the noise.

#### Method Used to Reduce the Surge Current

Surge currents may occur in the phase-lead capacitor of the power system, causing an overvoltage when the drive is stopped or at low loads.

It is recommended to add a DC reactor to the drive.



Smarter. Greener. Together.

## Industrial Automation Headquarters

### Delta Electronics, Inc.

Taoyuan Technology Center  
No.18, Xinglong Rd., Taoyuan City,  
Taoyuan County 33068, Taiwan  
TEL: 886-3-362-6301 / FAX: 886-3-371-6301

## Asia

### Delta Electronics (Jiangsu) Ltd.

Wujiang Plant 3  
1688 Jiangxing East Road,  
Wujiang Economic Development Zone  
Wujiang City, Jiang Su Province,  
People's Republic of China (Post code: 215200)  
TEL: 86-512-6340-3008 / FAX: 86-769-6340-7290

### Delta Greentech (China) Co., Ltd.

238 Min-Xia Road, Pudong District,  
ShangHai, P.R.C.  
Post code : 201209  
TEL: 86-21-58635678 / FAX: 86-21-58630003

### Delta Electronics (Japan), Inc.

Tokyo Office  
2-1-14 Minato-ku Shibadaimon,  
Tokyo 105-0012, Japan  
TEL: 81-3-5733-1111 / FAX: 81-3-5733-1211

### Delta Electronics (Korea), Inc.

1511, Byucksan Digital Valley 6-cha, Gasan-dong,  
Geumcheon-gu, Seoul, Korea, 153-704  
TEL: 82-2-515-5303 / FAX: 82-2-515-5302

### Delta Electronics Int'l (S) Pte Ltd

4 Kaki Bukit Ave 1, #05-05, Singapore 417939  
TEL: 65-6747-5155 / FAX: 65-6744-9228

### Delta Electronics (India) Pvt. Ltd.

Plot No 43 Sector 35, HSIIDC  
Gurgaon, PIN 122001, Haryana, India  
TEL : 91-124-4874900 / FAX : 91-124-4874945

## Americas

### Delta Products Corporation (USA)

Raleigh Office  
P.O. Box 12173, 5101 Davis Drive,  
Research Triangle Park, NC 27709, U.S.A.  
TEL: 1-919-767-3800 / FAX: 1-919-767-8080

### Delta Greentech (Brasil) S.A

Sao Paulo Office  
Rua Itapeva, 26 - 3º andar Edificio Itapeva One-Bela Vista  
01332-000-São Paulo-SP-Brazil  
TEL: +55 11 3568-3855 / FAX: +55 11 3568-3865

## Europe

### Delta Electronics (Netherlands) B.V.

Eindhoven Office  
De Witbogt 20, 5652 AG Eindhoven, The Netherlands  
TEL: +31 (0)40-8003800 / FAX: +31 (0)40-8003898

\*We reserve the right to change the information in this catalogue without prior notice.